

HENRY WEBER

CELEBRATING 40 YEARS OF
AEROSTARS 1968-2008



AEROSTAR

- THE AEROSTAR LOG -

THE MAGAZINE OF THE AEROSTAR OWNERS ASSOCIATION
VOLUME 37 | NUMBER 4 | FALL 2008





PUBLISHER WINSTON MEDIA

427 South Boston Ave Suite 509, Tulsa, OK 74103
918.582.9898
www.winstonmedia.com

CONTRIBUTING WRITERS Ken Bacon, Bill Brigdes, Jim Christy, Lester Kyle,
Tom Chappell, Dave Duntz, and Forrest Ward

OFFICERS President: David Duntz

3406 Darbyshire Dr, Beaver creek, OH 45440
937.912.5584
dduntz@woh.rr.com

Secretary / Treasurer: Rob Becker

1029 White Pine Drive, Grand Rapids, MI 49544
616.669.5170
beckerrob@yahoo.com

Association CPA: Jerry Buren

92 Country Club Drive
Monroe Township, NJ 08831
732.656.7630
732.656.7630 (FAX)
jibcpa@earthlink.net

**OFFICE OF
THE EXECUTIVE DIRECTOR**

Ken Bacon

2608 West Kenosha, #704
Broken Arrow, OK 74012
918.258.2346
918.258.2346 (FAX)
918.625.3161 (HOT LINE)
aoa2007@cox.net
www.aerostar-owners.com

DIRECTORS Rob Becker, Robert Bliss, Jerry Buren, Dave Duntz,
Jim Hudgin, Karl Hutter, Jim Moore

ADVERTISING RATES See page 52



OUR APOLOGIES:

We endeavor to provide correct information with our pictures; however, we made an error describing the Spring Issue Cover Photo. It should have listed Genny and Langdon Badger's Aerostar as 600A VH-UUV.

DISCLAIMER

The comments, articles, stories, letters, and information contained in this magazine are the personal opinions of the writers and are not - nor are they to be construed as - official policy or commentary of the Aerostar Owners Association. Neither the Association nor its officers, directors or the magazine editor or publisher give any official sanction to any articles, stories, letters and information contained herein.

THE PILOT-IN-COMMAND IS RESPONSIBLE FOR THE SAFE AND PROPER OPERATION OF HIS/HER AIRCRAFT, AND IT IS THE RESPONSIBILITY OF THE PILOT-IN-COMMAND TO OPERATE THAT AIRCRAFT IN COMPLIANCE WITH THAT AIRCRAFT'S PILOT'S OPERATING HANDBOOK AND OTHER OFFICIAL MANUALS AND DIRECTIVES.

TABLE OF CONTENTS

Features

- 03 HOW TO FIND AN OIL LEAK
- Bill Bridges
- 05 WINTER FLYING CHECKLIST
- Jim Christy
- 09 HENRY WEBER BIOGRAPHY
-Dave Duntz
- 17 BERMUDA
- Forrest Ward
- 27 WHAT'S YOUR MISSION?
-Ken Bacon
- 35 WHAT ABOUT THOSE CRANKCASES?
- Ken Bacon
- 41 CONTINUING THE AEROSTAR STORY
-Aerostar Log 1974

Departments

- 01 PRESIDENT'S PAGE
- Dave Duntz (Our 37th President)
- 15 AEROSTAR SCRAPBOOK
- 08 WELCOME NEW MEMBERS
- 40 ICE MAN COMETH
- Lester Kyle
- 37 INSURANCE
- Thomas H. Chappell
- 50 @ YOUR SERVICE
- 52 CLASSIFIED ADVERTISING
- 52 CALENDAR
- 52 ADVERTISING RATES
- 52 INDEX TO ADVERTISERS

AOA WEBSITE

www.aerostar-owners.com

918-625-3161 (Hotline Number)
kenbaconjr@cox.net (for Ken Bacon)
aoa2007@cox.net. (for office)



PRESIDENT'S PAGE



We received lots of positive feedback from members about our super 52 page Summer 2008 issue of the Log. Many thanks to authors Bob Behrens, Giandrea Caravatti, Sergio Dallan, Lester Kyle, Ken Bacon and Tom Chappell for great substantive articles and from the many members that sent us photos of the midyear and for the Scrapbook. A special thanks to Burdella Bacon who pulled it all together and also released the creative juices of some very talented folks at our publisher Winston Media. Heck, I couldn't be more proud and I have been handing them out to anyone who wants to know about the Aerostar or AOA like a new father passing out cigars! Let's keep the Log useful and informative with more great articles and photos from you!

I hope you enjoy the article about Henry Weber in this issue as much as I enjoyed learning about Henry. He is one of many who helped in the early days of our association and has personally brought many owners into the fold. I remember right after I purchased my Aerostar in 1994 calling Henry for some advice. He was very helpful and generous with his time. He has always been a strong supporter of AOA. I am very pleased we're able to celebrate 40 years of Aerostars with Henry (and 38 years as an AOA member) and honor him with an AOA Lifetime Achievement Award.

I am writing this in September to meet our printing deadlines so our 38th annual convention in Orlando has not yet happened. However it will be history when you read this. I am impressed with the agenda that Ken and Burd have put together and know it will be a great event. I am especially pleased and honored that Ron Smith, former President of Ted Smith and Associates and manufacturer of the Aerostar, will address our group. We will have full coverage and photos in our Winter 2009 Log.

As you know the President of the National Business Aviation Association (NBAA), Ed Bolen, was very generous to us providing a day at their annual convention in Orlando at no charge to any of the attendees at our Orlando convention. Thank you Ed for making our convention even better and making it a win-win for all of us. If you liked what you saw on NBAA day you will really like our 2009 Midyear in San Diego! Our event will coincide with the very first NBAA Light Business Airplane Exhibition and Conference Thursday March 12 to Saturday March 14 at the San Diego Convention Center. This premier national event will include 50 aircraft on static display, hundreds of exhibitors and over 25 forums. Plenty of social activities will be available for fun as well. Complete details will be in the Winter 2009 Log but circle your calendar now so you can save the dates! Need to know more now? Go to www.nbaa.org/light for the latest.

If you haven't been on the AOA website lately you have missed several great discussions on our Members Forum and possibly something you need at the Aerostar Mart. By the way, there is no charge to list items for sale on the Aerostar Mart. Think of it as a free ebay just for Aerostar owners. Another example of members helping members who are all part of a great group of folks enjoying the privilege of flying the fastest piston business twin in the world.

Blue skies,

The Best Simulator Training The Best Price The Best Staff

Recurrent Training Center has the best simulator training available. Unlike our competitors, our course curriculum focuses on proven high risk areas such as engine failure, flight instrument failure, thunderstorm hazards, low visibility approaches, and communications failures. Ask yourself, how would you react during a partial panel or communications failure? Our competitors don't teach you how to handle these events. RTC does.

Our instructors are knowledgeable professionals with many years of flying experience. All training is done "one-on-one" and all the focus is on you! We offer the most up to date instruction, and the latest course materials.



More Simulator Time

You come because you recognize the importance of training in a simulator, yet our competitors offer only a minimal amount of flying time in the simulator. We offer 50% more simulator time, 9-10 hours versus six.



FAA Approved FTD's

The Best Price

RTC has proven for eighteen years that we provide the BEST training. More importantly, we do it at the BEST price. Our prices are less than half the cost of the competition!

Aerostar Recurrent	\$1350.00
Aerostar Initial	\$1755.00

Initial Transition & Annual Recurrent Training For:

Aerostar
Cessna 300/400 Series
Cessna 182,206,210
Cessna Skymaster C337
Beech Bonanza
Baron 55/58
Beech Duke
Beech King Air 90, 100, 200
Piper Navajo
Piper Seneca
Twin Comanche
Mooney

Recurrent Training Center, Inc
Champaign, IL

1-800-727-1014
www.rtcpilot.com

Insurance Approved Courses

How To Find an Oil Leak

By Bill Bridges

Oil leaks can definitely be frustrating just when you think you've got it taken care of it either pops up in the same place again on the next flight or mysteriously moves to a new spot or shows up in the other engine. If you're not sure where to start I suggest cleaning the engine thoroughly then spray developer around suspected areas. The back of the engine is usually the hardest to get to where the developer works best. Do a quick run up and follow the oil trail left in the developer (remembering oil never runs up hill).

- Flap and down the fuselage-is most likely a shaft seal leaking which comes out the little drain lines. Two drain lines on the right engine one fuel pump, one hydraulic pump and left engine fuel pump only.
- Oil out the side of the cowlings-could be rocker cover gaskets.
- Oil puddles in the bottom of the cowling could be various items depending on where they are located. Such as large turbo fitting will leak when hot, magneto gasket, oil filter adapter, loose or broken hose/fitting, cylinder base o ring.
- Oil drips on the floor could simply be a leaking quick drain.
- Oil on the top of the engine could be loose dip stick, top of center case leaking or the through bolts, push tube seal or in some engines the metal retainer in which case changing the push tube seals won't fix that you'll have to remove the retainer and reseal it.
- Oil in the front nose bowl-usually the center case seal on the bottom.

A couple of pointers when you need to seal the case: we always use an epoxy first to seal quickly then cover with a tank sealer; if you use the tank sealer first it will draw the oil out. When tackling an oil leak that you know for sure is coming from the breather the Aerostar Aircraft breather kit is a good investment and if all else fails and nothing seems to work in stopping those pesky oil leaks Lycoming's number is 1-800 I need new engines.



Fuselage

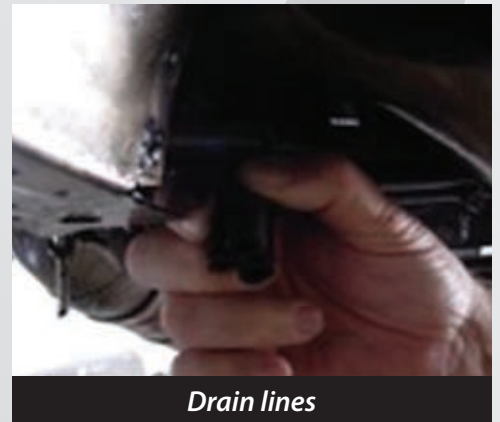

Drain lines



Scavenge pump adapter



Scavenge pump seal leaking
(Could also be fuel pump seal leaking)



Bottom cowling

The Flight Shop, Inc.

Aerostar Specialist since 1969

From rebuild to resale we're your source for Aerostar maintenance and parts.

- ▶ Annuals - pre-buys
- ▶ Modifications - Upgrades
- ▶ General service - maintenance
- ▶ Largest in house supply of Aerostar Parts - new, used, overhauled, PMA'd, STC'd



N7400S in restoration stage



N6ZR 1980 601P for sale

435-723-3469 phone 1780 North 2000 West, Hangar #21 Brigham City, UT. 84302 435-723-1736 fax
email: sales@theflightshop.com, bill@theflightshop.com, craig@theflightshop.com
www.theflightshop.com

BILL BRIDGES BIOGRAPHY



Bill Bridges has been servicing, rebuilding and modifying Aerostars for almost 40 years. His facility was one of the first Aerostar Service Centers and was a Piper Service and Parts Sales Center. The Flight Shop is a family plus owned business.

WINTER FLYING CHECKLIST

*Good Maintenance and Proper Equipment
Are Essential for Safe Winter Flying*

by James S. Christy
Vice President of Aerostar Aircraft Corp



Winter Weather is hard on your Airplane!

As pilots we're all aware of the importance of deicing our airplanes before takeoff and proper preheating of the engines before attempting a start. Before you head into cold weather you could also make sure your landing gear is properly serviced and not leaking. Cold weather can contribute to a leaking strut going completely flat, and any flat strut is a no go item. The reason is that the landing gear will not absorb the shock of landing and parts could be overstressed. In addition if the nose strut is flat you may lose directional control on the touchdown due to the strut not centering. If you have the newer style Wiebel nose gear you should also assure compliance with AD 94-15-13 requiring installation of Aerostar Service Bulletin 600-128 kit. The AD says it is required within 100 hrs: "To prevent failure of the nose landing gear caused by frozen moisture within cylinder which could lead to nose gear collapse"...

Known Icing Certification

If your Aerostar is already equipped with items 1-6 in the accompanying checklist you can upgrade to known icing certification today, because items 7-14 are in-stock and available in kit form for field installation. Item 7 windshield Anti-Ice has also been upgraded from a heated Plexiglas panel to Glass providing greater long-term clarity. Even if your Aerostar is properly equipped and certified for flight into "known icing condition" be sure you thoroughly read the flight manual supplement and operate the aircraft in accordance with that information.

Known Icing Checklist:

1. Heater
2. Defroster
3. Prop Deice option 4
4. Surface Deice option 79
5. Wing Ice Light option 5
6. Equipment for Night IFR Flight
7. Electric Windshield Anti-ice option 126 or Alcohol Deice option 121
8. Static Discharger Wicks option 144
9. Electrical Bonding Straps
10. Manifold Nozzle Vent Retrofit Kit option 213
11. Mod Kit Engine Known Icing Protection and Inboard Wing Deice
12. Alternate Induction Air Left and Right
13. Ice Impingement Devices Left and Right
14. Aircraft Flight Manual Supplement # 196



Jim Christy & Dick Taylor after landing at O'Hare

A few years ago Jim Christy made a trip to Chicago with Dick Taylor in Dick's Aerostar. Dick Taylor's Aerostar is the last 1983 602P airframe manufactured. Aerostar Aircraft converted Dick's Aerostar to a 700 with TIO-540-U2A 350 HP engines. It is certified for flight in known icing, of course, with the glass hot plate windshield anti-ice. These are photos of Dick Taylor's airplane after landing about midnight at O'Hare in Chicago.

Jim Christy reports, "Tops were 9,500 ft. and we did a 45 minute descent and approach. We cycled the boots about 6 or 8 times and that kept the booted areas very clean. We maintained about 160 KIAS until inside the outer marker and broke out at about 500 ft. On the ground it was light to moderate snow. The next day we flew down to San Antonio for the AOA meeting. The hardest part was taxiing to the active runway at O'Hare." Pictures courtesy of Jim Christy





Aerostar World, Inc.

DON SMITH
PRESIDENT



Aerostar World was incorporated in 1981 with the concept of a personalized shop for the Aerostar owner. With this idea in mind, our company has been greatly successful and now has over one hundred Aerostars on a regular maintenance basis. Our success is owned to many factors with the most important being that of high quality maintenance and knowledge of the Aerostar, with two original Ted Smith Aerostar factory employees now on staff. Utilizing this expertise, we can give you the best performance and safety that this fine aircraft has to offer.

Distributor and Service Center for:

- Mache, Inc.
- ACF-50 Corrosion Block Treatment
- Power-Pac Spoilers

Also:

- Custom Exterior Placard Kits (color-keyed)
- Pre-purchase Inspections and Import/Export C of A's
- Aircraft Sales
- Aircraft maintenance, inspection, modification, repair, updates

Call Us For All of Your AEROSTAR PARTS Needs
P.O. Box 9044 • Dothan, Alabama 36304
(334) 983-5600 • FAX (334) 98304314

When Proficiency and Safety Matter

**Initial, Recurrent &
Advanced Avionics
Training**

Insurance Approved

**Ground & Flight
Training Curriculumms**

ATM Offers You...

- ✓ Training at your location, on your schedule
- ✓ Insurance approved programs
- ✓ Best value for your training dollars
- ✓ Convenient, safe, professional
- ✓ Dual instruction in your aircraft
- ✓ Competitively priced
- ✓ One-On-One training
- ✓ Manuals, flight reviews & IPC's provided



(772) 778-7815
www.flyATM.com

Post Office Box 1234
Willoughby, OH 44096-1234
Email: contact@flyATM.com

FALL
2008



Welcome

NEW MEMBERS!



The Association would like to welcome all of our new members who have joined since the previous edition of The Aerostar Log was published. Hope to meet you at the Annual Convention. We would also like to thank those members who have made referrals. (August 31, 2008)

**Charles & Lynn
Couch**
*Irving, TX
N711YM*

**Wilfred & Jennifer
Ferguson**
*Richfield, OH
N62WF*

**Chris & Sommer
Hill**
*Johnson City, TN
N601TE*

**Richard Gayles &
Daryth Stallone**
Merritt Island, FL

Jeff Helmericks
*Palmer, AK
N564RA*

Lowry Watkins
Louisville, KY

AOA WEBSITE

www.aerostar-owners.com

918-625-3161 (Hotline Number)
kenbaconjr@cox.net (for Ken Bacon)
aoa2007@cox.net. (for office)



HENRY WEBER

**AEROSTAR SALESMAN EXTRAORDINAIRE
CELEBRATING 40 YEARS OF AEROSTARS**

by Dave Duntz



Photos courtesy of Henry Weber and Dave Duntz

It was 1968. Since 1964 the new Aerostar line of business aircraft had received a lot of favorable publicity in the aviation press. A new era of aircraft design, conceived by Ted Smith, noted designer of the Aero Commander, would use a sleek common airframe to produce numerous types of aircraft from a single engine piston to a twin turbojet. Development had been rapid and exciting. The first to fly was the piston twin, prototype model 320 with 160hp engines in September 1966. Groundbreaking for the new production plant at Van Nuys Airport was in August 1967. The prototype model 600 (prototype airframe number 2) with twin 290hp engines first flew in December 1967 and the plant started production in February

1968. These were heady times of great progress and anticipation.

To get a flight in an Aerostar at that time was greatly sought after and very rare. Henry Weber was one of the fortunate few. He not only enjoyed the Aerostar, he was certain the plane was a winner. Faster and sleeker than any Cessna, Piper or Beach, and oh, what beautiful handling! He wanted to become an Aerostar dealer.

The Reading Air Show, in Reading, Pennsylvania, was scheduled for June 1968. Back then this was the American version of the Paris Air Show and featured



Henry presents new Aerostar keys to the Canandale Company

static displays and flight demonstrations attended by thousands. Boyd Lydick, Chief of Flight Test, and the Aerostar 600 (the prototype, now factory demonstrator N588TS) wowed the crowds. Ted Smith attended with wife Vernita and Sales manager, Tom Sim.

What happened at Reading is perhaps best told by Ted Smith himself. From his unpublished memoirs Ted wrote: "About noon time a person by the name of Henry Weber came up to talk about the airplane and told us he was interested in becoming a dealer for the fine airplane he saw and had ridden in, stating that he was from Lancaster, Pennsylvania and was a dealer for the Mitsubishi MU2 and the Mooney and would like

to add the Aerostar to his line. My statement to Henry was that on this trip we were just showing the airplane and were not quite ready to appoint dealers, although we had quite a list of people who had expressed an interest in becoming dealers including some of our old Aero Commander dealers. Vernita was with us and I introduced her to Henry. Vernita made a casual remark that she would love to see more of Pennsylvania as flying over it she thought it was a beautiful state and it is. So Henry pops up and said to Vernita that he would be glad to take her for a tour around and over Pennsylvania in his MU2 and they could land along the way and he would show her the pretzel factories and some of the old Pennsylvania Dutch farms. Henry



Henry Weber with his first Aerostar

immediately had a taker, so he and Vernita took off in the MU2, stopped at various places including the pretzel factory, had lunch together and got well acquainted to the point where Vernita was really sold on Henry and expressed the opinion that she thought Henry would be a good dealer for the Aerostar and she also expressed the same opinion to Tom Sim. Tom and I both told Henry that we would give him every consideration, but Henry was ready to go and did not want to wait. So again Vernita spoke up saying she thought we should appoint Henry a dealer now—then and there. So I said OK; Henry we do not have the dealer agreements with us, but you are our first dealer. As it turned out the decision was one of the best we had ever made. To bind the deal, Henry pulled out his checkbook and wrote a check for \$30,000 as deposits for six Aerostars.”

THEY SOLD AS FAST AS HE COULD GET THEM

So began an experience of a lifetime. His first Aerostar was production airplane number two. With his enthusiasm for the plane together with the eye watering performance of those early stock 600's (which were so lightweight) Henry quickly learned that after a demo flight almost everyone ordered a plane. They sold as fast as he could get them. Soon after he started showing the plane he had 3 demos in one afternoon. All 3 bought a plane. One was World War II fighter ace George Bard who said “I want this one.” Henry said he

would make sure he got the next plane delivered. No, he wanted the demo plane. Since he was actively showing the plane Henry didn't want to part with his very first plane. But always wanting to make the sale and please his customers, Henry sold him the plane and the gentleman agreed to allow Henry use of it till his next delivery arrived. In 1969 and 70, the first years of aircraft deliveries, Henry sold 30 % of all Aerostars produced. He received the Aerostar Sales Achievement Award for both years. Then Butler bought the company and production at Van Nuys stopped.

HENRY'S SUPPORT FOR THE AEROSTAR LED TO ACTION

All production equipment was moved to Texas to consolidate manufacturing with Mooney, which they had previously purchased. When Butler could not make their loan payments they alleged corrosion problems and asked the FAA to ground all Aerostars, suing American Cement, the previous manufacturer of Aerostars. This put existing owners in a bind. Henry joined with other Aerostar owners to take action. On March 21, 1971 Henry hosted the first Aerostar Owners Association meeting in Lancaster to unite the owners against Butler. Ted Smith was there. Ted explained that the Aerostar exceeded all FAA corrosion control requirements. It was found that except for just one example of minor corrosion there was no corrosion in any airplane. Countersuits by owners and dealers for Defamation of Property were discussed at this meeting. Butler lost its suit against American Cement. Ted eventually bought back the company and started production in 1973. Henry's support of the AOA and Aerostar owners never wavered. He is still a member of AOA 38 years later, has attended dozens of conventions and helped numerous members.

Henry was also a strong company supporter, more so than even your average dealer. He not only believed in the plane but the people who built it. In the days when the company struggled to meet their financial obligations Henry could be counted on to pay for the plane before it was finished. While Butler owned

Aerostar, Ted Smith was busy developing an STC to the 601 to pressurize the plane. To assist Ted, Henry provided his 601, serial number 61-0034, N7455S and paid for the work. This initial STC was good for 3.2 psid and it was later increased to 4.25 psid. Of course this became a highly desirable airplane and Henry quickly sold it. The STC was the basis for the future 601P.

HENRY AVERAGED OVER AN HOUR A DAY IN THE AIR FOR 60 YEARS

Henry did a lot of flying as part of his Aerostar and Mooney sales (he was the first MU-2 dealer in the US and had the first MU-2 in the US.). In fact for years it seemed he was never home. Every time he bought a new plane he would fly across the country to Ker-ville, Texas, Van Nuys or Santa Maria, California, or Vero Beach, Florida and fly it home. (During those years he got to know a young man working in the Customer Delivery Center at Santa Maria very well. His name was Jim Christy and today he is Vice President of Aerostar Aircraft.) He also used Aerostars to fly charter and for many years did a lot of the flying himself. Among his most memorable passengers were Barry Goldwater and Ollie North.

All this flying added up. By 2004 Henry had 23,520 hours that included 1000 hours of instructing. He decided to stop flying as pilot in command because at 83 his hearing was not what he wanted it to be. That culminated a lifetime of flying spanning 60 years; an average of flying over an hour a day for the entire pe-

riod despite the fact he was grounded for one year for cancer. His first lesson was in a J-3 Cub in August 1944. He got his private in October 1945 and eventually earned commercial, instrument, CFI and CFII. When he earned his multi in 1954 he took the flight test in a Bamboo Bomber. After takeoff from Baltimore it started to smoke from behind the instrument panel. Henry told the examiner he was returning to land and calmly did so even though the smoke continued. After landing the examiner said he had handled the plane well and gave him his ticket. Quick check ride! Tempting fate again, he proceeded to earn his rotary wing commercial in 1963 and rotary wing instructor in 1964, both in a Brantly.

HENRY SOLD ONE EIGHTH OF ALL NEW AEROSTARS EVER BUILT

Henry grew up in the Lancaster area but he didn't always want to sell airplanes. At first he wanted to be a preacher but then decided to be a doctor, attending Mennonite College in Goshen, Indiana. During the war he served as a medical missionary and decided that medicine wasn't what he wanted either. After the war he started building homes and was very successful. But he had the flying bug so he bought a little grass strip called Garden Spot. He became a Cessna dealer and then a Mooney dealer. In 1961 he sold it and moved into a small hangar at Lancaster Airport. The photo of Henry with his first Aerostar shows the small hangar in the background. By the 1970's he needed a larger facility for performing Mooney and Aerostar maintenance so he built a new facility at

Lancaster that still houses the business today. He actively sold Aerostars until 2003 when he turned over his business, Henry Weber Aircraft distributors Inc, to his sons in law Dorn Clare and Steve Gerz. In that 35 year time span he sold 127 new Aerostars, accounting for one eighth (12.5%) of all Aerostar production. He also sold another 304 used Aerostars in those 35 years for a total of 431 Aerostars sold.

In addition to selling Aerostar number 2 and number 3 (N111TS), he sold Aerostar numbers 100, 200, 300, 400, and 500. He sold Aerostar 300 to Phil Claxton (a 1976, 601P, N300AM) who bought it specifically to break the around the world speed record, which he did (see the Summer 2008 Aerostar Log).



Henry Weber facility today at Lancaster Airport



Henry Weber and his wife Frances Mae in 1989

Henry and wife Frances Mae have two sons and three daughters and are grandparents to seven grandchildren. Henry has been recognized with the FAA Master Pilot Award for 50 years of accident free flying, AOPA Certificate of Achievement for 60 years of membership, and the Aerostar Owners Association Life Time Achievement Award presented at the 2008 annual convention in Orlando.

Now, at age 87, he still gets excited talking about the Aerostar. When I asked Henry his thoughts about the Aerostar it was evident that his Aerostar loyalty was anchored in his strong belief in the airplane. "I don't think there is a plane built that is as well designed as the Aerostar." In fact he loves to fly the 600 just to fly. "Crank it up and it goes." But if he is taking a trip with his family he prefers a 601P. The one item he was not fond of was the Piper water rudder (ventral rudder). "Thank goodness for Machen and their STC that could replace it. Of course Piper eliminated it in their 700P by using counter rotating engines." He has also seen the jet mod that Aerostar Aircraft is developing. "It will be the neatest and sweetest little jet in the world. If I was ten years younger I would buy it."

To sum all that has been said of Henry, no one did it better than Ted Smith by concluding his story about Henry with the following thought, "So Vernita was right; he did not only make a good dealer, but the best."

High praise from the master himself. And so true!

Are you puzzled by Aviation Insurance?



Tom Chappell

Now more than ever, it's important to understand your insurance policy, and we're here to help you!



**Call our staff today
for a free evaluation
and quote.**

NASHVILLE
800.999.1109

ATLANTA
800-761-2557

www.aviationinsurance.com

Aerostar Covers

800/777-6405



- Cabin Covers
- Engine & Wing Covers
- Engine Plugs
- HeatShields

Bruce's Custom Covers

www.aircraftcovers.com



Business Aircraft Center, Inc., (BAC) is a full-service FBO on the Danbury, CT (DXR) Airport, specializing in Aerostar sales.

AIRCRAFT NOW AVAILABLE FOR SALE

1. 1981 602P/700. Appr. 2775TT! 1495/195 SFOH (U2A engines)! 3/09 Annual . 5.5 psi! New paint! New leather interior! Known Ice! Air-conditioned! Garmin 340/530/330 plus full King Silver Crown package, including KFC200AP/FD w/EHSI; KAS297B alt alert/preselect; KRA10 radio altimeter; RMI, Coloradar. GEMonitor. Aux fuel! Much more!

2. 1977 601P/700. A STUNNING SUPERSTAR WITH ONE CAREFUL OWNER FOR THE LAST 20 YEARS! 3689TTA. 384 SMOHLE (U2A)/1293 SFOHRE (U2A). 91 SPOH. Annual 7/08. Air conditioned. Known Ice. Incredibly loaded...GARMIN, AVIDYNE, KFC200 AFCS w/KAS297B ALT ALERT/PRESELECT; WX1000+, dual XPNDRS and HSI's, Long fuel, big brakes, Plastech curtains, NEW PAINT/LEATHER INTERIOR IN 2007! Much more! Hangared. Owner bought turboprop and is motivated!

web site: www.businessaircraftcenter.com

email: bacz@aol.com

"Aerostars are the most fun you can have with your clothes on"

81 Kenosia Avenue • Danbury, CT 06810 • (203) 748-7000 • FAX 790-9000
SALES • SERVICE • REFUELING • HANGARS • TIEDOWNS • OFFICE LEASING
1983 - 2008 • BAC's Silver Anniversary • Thank you!

AEROSTAR SCRAPBOOK

Dave Duntz's 1980
Piper Aerostar 600A ▶



▲ Left to Right-
Peter & Gail Urquhart (New
Zealand), Ann & Steve Womack
(Grayson, KY)-Ann & Steve
were in New Zealand for a
Harley Motorcycle Adventure

Tom & Rebecca DeBrocke ▶
with N78LS



William & Karren
Blatter's 1978 601P ▶



◀ Ron Turner in his 1974 601A
▼ John Benson in a 1947 Grumman
Widgeon, over Vanderbilt Beach,
Naples, FL



TRAVEL

*“Can You Take Us
To Bermuda?”*

By Forrest Ward

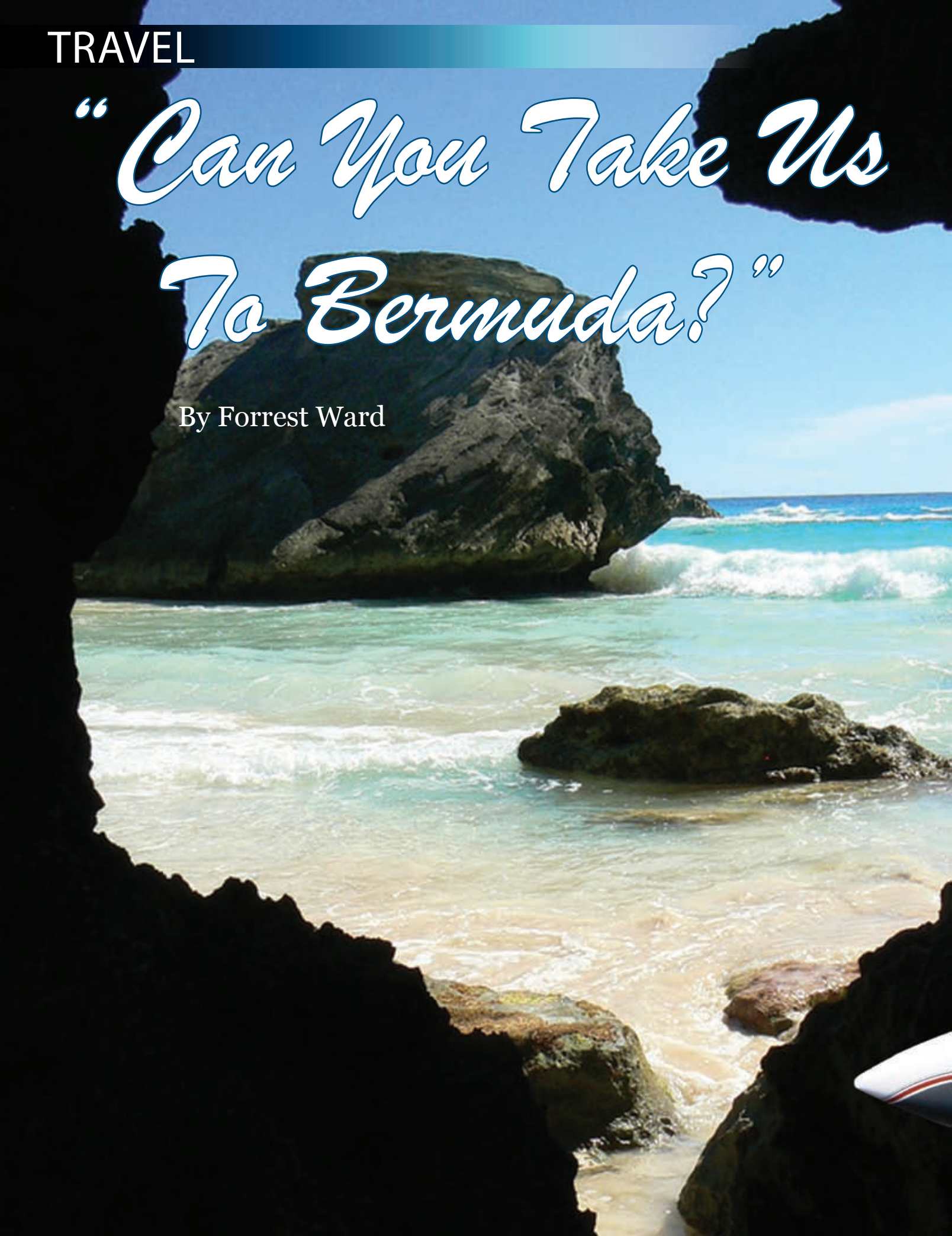



A couple years ago, when I was still considering the pros and cons of becoming an Aerostar owner, my wife, and one of her friends, and I were enjoying dinner together, the friend asked “Could you take us to Bermuda?”

That question kept nipping at the back of my mind. What would be involved with making the trip? I went on-line and learned that no AVGAS was available in Bermuda. Well, that was a problem.

Then I called New York Center and learned about another problem: My lack of an HF radio, and the resulting gap in communication meant I could not legally complete the flight under IFR. And, the rules say: if I want to fly higher than 6,000', I would need to be on an instrument flight plan. So any flight would be at 5,500' eastbound and 4,500' westbound. The nice fellow at NY Center said, he received calls periodically from pilots interested in flying to Bermuda, but no one ever actually went.

OK, now I had a problem, an obstacle, a less than ideal option, and a challenge.

“No one ever actually went”.

Problem: No Fuel

I had this idea that there must be someone who would ship sealed barrels of 100LL. After days of phone calls and dead ends, I determined that someone was me! I located a source of barrels, hazardous material labels, a barrel wrench, a pallet, shrink wrap, and a method of securing the barrels to the pallet. I found an outfit that would haul the barrels to New Jersey, to connect with the shipping company that has a weekly run

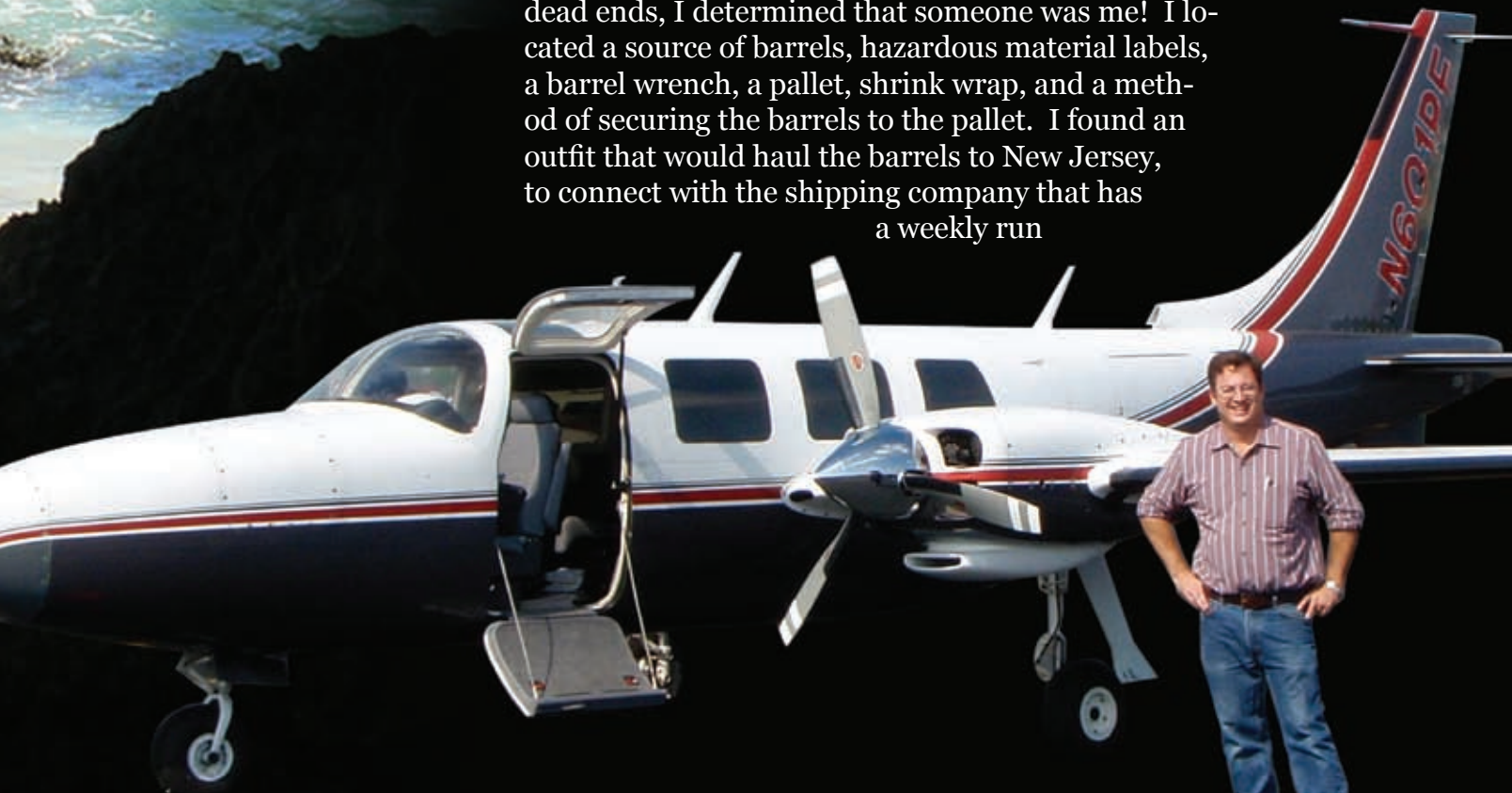

to Bermuda, and another company in Bermuda to get the fuel through customs, and up to the airport, and to a small FBO who would receive and hold the fuel for me. All I had to do was pick up the barrels, secure them to the pallet, fill them with 100LL, label and wrap, and load them on the truck (and wire a bunch of money to a Bermuda Bank account, to cover the cost of shipping & handling). Three weeks later, the shipper said my fuel was in Bermuda!

Obstacle:

ATC say no IFR flight without an HF radio.

I talked with my contact at NY Center; he said he had no problem with me making the trip at any altitude up to FL250, he said the air space was empty, and he'd be happy to block off the entire route for my trip. But, he needed a waiver from the communication requirement of FAR 91.183. He said I should contact my local FSDO for a waiver. He cautioned me that he'd sent previous callers to their FSDOs, none had ever returned with a waiver.

I did my homework, I studied the regulations, and I had a verbal approval from the Operations guy at NY CTR. I knew my request was reasonable, it should be apparent that it is safer for me to be in the system, and out of communication for only a limited time period, instead of for most of the flight.

First the fellows at the FSDO said they would check in to my request. Nothing, then they said I did not need a waiver, ATC could allow me to go knowing there would be a gap in communication; finally, they said that I was requesting to violate a regulation, that they could not waive, because, they did not know what the regulation was. This did not look good....



I called Senator Webb's office, explained my issue, and forwarded my official request for a waiver from FAR 91.183. That got the ball rolling. The folks at FAA Regulations Washington DC got involved, and decided the answer was "NO". The controlling regulation was not 91.183; it was ICAO Annex 2 (Rules of the Air) 14 CFR 91.703.

Less than ideal option: Back to plan "B". VFR at 5,500'

Bermuda weather is generally beautiful, but they get occasional rain squalls which temporarily reduce visibility, and lower ceilings below VFR minimums.

My friendly flight service briefer helped me with this one. I filed a VFR flight plan from Norfolk to Bermuda, and an IFR flight plan from LGA to Bermuda, departing about one hour before I was scheduled to arrive in Bermuda. All I had to do was depart VFR, fly VFR for 600 miles, contact NY CTR, and if needed, pick up my IFR flight plan.

Challenge:

I chose to travel alone. My family and friends were already in Bermuda, enjoying the weather and the beautiful water.

I loaded up with max fuel, and launched at 4:50 AM to beat the lower forecast for afternoon weather, and headed across. I talked with tower, Norfolk Departure, and "Giant Killer" (the radar covering the Virginia Capes), then nothing. Just waves, clouds, haze, and a few rain showers. The radio was quiet except for a few calls from commercial jets; I was able to get one to relay my position to NY Center, who seemed to have forgotten about me. Closing in



on Bermuda, a large storm was covering the north & west side of the island, the reefs were visible, the land was not, I swung around to the right, and as I came around the side of the weather, the island came into sight, the sun was shining through the clouds and the green of the trees and the white of the beaches and the blue of the water was amazing. At 1500', I could see everything, I worked back around and soon I was lining up on the airport. Cleared to land by a friendly tower controller, rolling out on a smooth runway and I was taxiing in to parking.

Visiting Bermuda:

Bermuda Customs was friendly, and quick. The Sovereign Flight Support Staff were professional, and had me in a taxi heading to 9 Beaches in less than 15 minutes. No lines, no waits, and no worries!

The high point of my visit was the Bermuda Cup Match. I attended the 2nd half of the second day, and it was wild. The game was Cricket, and the match was between St. George and Somerset. As I was staying in Somerset, I became a rabid fan. The two day match ended in a draw, which did not seem to dampen anyone's enthusiasm. The crowd was in a Marti Gras frame of mind. The match marks a Bermuda National Holiday, and everyone either attends the game, or camps out in tents and listens on the radio. Most of the taxis are off the road, so we were lucky to be staying so close to the match.

The party is over:

Monday, the party was over and it was time to start back. The return had to be at 4,500' and I was going to be fighting a headwind. We spent an hour pumping fuel with a hand pump. The guy at Sovereign Flight Support is investigating stocking AV-GAS, to support transient flights, and maybe a flight school.

I filed DVFR and IFR flight plans: IFR to depart Bermuda Airspace, and DVFR to give search and rescue an idea where to look if I failed to show up in Virginia. The westbound was much like the flight over, except it was 5.1 hours long! I set 55% power, leaned for 1550 TIT, and ended up landing with 51 gallons aboard. The great thing about the 601P is its flexibility. There is no substitute for its range at any altitude.

Lessons learned:

1. Bermuda is a wonderful Aerostar destination.
2. Knowing what I know now, I wasted a lot of time messing with the FAA trying to get them to waive a rule that it turned out wasn't applicable to 90+% of my flight.
3. The fuel shipment would be easier next time, or for the next guy, because I've figured out how to get it done.
4. The low altitude option works, and kept me legal, but it added a lot to my time enroute.
5. A 5.1 hour flight is longer than most folks would want to spend away from a rest room.

Would I make the trip again?

Yes, if

If I can get that portable HF radio from Eastern Avionics to work, I'll do this trip again.

If I can work out the fuel issue, I'll buy that life raft and EPIRB (instead of renting), and start making regular flights.



United States to and from Bermuda Via Small Aircraft Flight Hints and Suggestions

By Forrest Ward

Please do not take my word on any information presented here, regulations change, and interpretations change; check for yourself.

Preflight Planning is the Pilot in Command's responsibility!

If you want to fly at an altitude higher than 5,500' Eastbound and 4,500' Westbound, you have to be on an IFR flight plan, and being on an IFR flight plan requires that you maintain a continuous watch on the assigned frequency, and be able to receive communication from NY Center at all times.

The only way to be legal is to have an HF Radio.

A sat phone is not allowed as a substitute.

A portable HF may make you legal. Eastern Avionics sells a KENWOOD EA-480 HF radio (\$2,895.00) that may meet the requirements. Their description says: "This system is not FAA approved for installation in aircraft." Talk with your avionics guru.

If flying 600-700 miles over water, at fairly low altitude, with minimal communication, and dealing with enroute weather yourself, doesn't bother you, read on:

Bermuda is beautiful and the flight is an amazing experience.

First the players: You and your aircraft, and ATC



You should be a current (and capable) instrument rated pilot; even though you will be on a VFR flight plan; haze, scattered clouds, limited light and unexpected conditions of reduced visibility are a real possibility, this is no place for a VFR only pilot.

Jeppesen can provide you with a chart pack that will give you anything you need. I have the electronic charts on my MX20, and they added the Caribbean for one cycle, after I did the down load, I was all set. I'm sure their paper option is equally good.

Get a good nights rest and eat and drink lightly, for the obvious reasons.

The plane: at a minimum

Needs enough range to make the trip with 50% worse winds than forecast, with enough reserve fuel to allow you to fly another 2 hours after arriving at TXKF.

The two hour number is from Overseas Territories Aviation Requirements (ASSI) 91.255 (c (2)) for IFR Fuel Requirements. This rule will allow you to pick up an IFR flight plan, if needed, once you are in radio range of Bermuda. Otherwise the only way in is on a Special VFR clearance, and depending on whether you have a commercial pilot's license the SVFR visibility requirements are either 3KM (about 2 miles) or 10 KM.





TXKF has several approaches, including an ILS, when a squall comes in; a SVFR approach would not be fun. This trip is supposed to be fun!

The plane should have the usual 2 NAV Coms, (I brought my hand held as well), and two GPSs, I had a Garmin GNS 480 and my trusty 396. If I lost both generators, and ran the battery dead, I would still be able to talk, and navigate.

My opinion is: If you will need it to complete the trip safely/legally, bring two.

Bring a life raft, EPIRB, and maritime survival kit.

If you want to rent, contact Survival Products 954-966-7329.

Call your insurance company to make sure the plane is covered for a trip to Bermuda.



ATC:

Flights out to 12 miles are covered under the same regulations as flights over land.

Flights between 12 miles and the start of the ADIZ (ZIBUT), on AR9, are controlled by “Giant Killer” (118.125). Coordinate with Giant Killer on when they want you to switch your TXP code to 2000. Beyond ZIBUT, and above FLO60, New York Center (133.5) is in control and all flights must be on an Instrument Flight Plan and follow the rules for an Instrument Flight.

Below FLO60, VFR, you are on your own.

Entering Bermuda airspace (180 NM from the TXKF) change the TXP code to 2100, the inner ring is 60 NM out, you should be able to reach New York Center (128.5) between 100 and 70 NM out, NY CTR will assign a TXP Code, and you will be able to pick up the ATIS.

Without a HF Radio, I monitored the appropriate Center Freq, 123.45 (air-air freq.) and 121.5. When I heard a commercial flight talking to Center, I wrote down their call sign and when I needed to relay crossing a way point, or approaching the ADIZ, I’d attempt to call them and get them to switch over to 123.45. Delta, US Air, and Air Canada helped, Jet Blue did not. If I am considering who to fly with on a commercial flight, I will definitely give preference to the folks who were nice enough to give me a hand.

I put two flight plans in the system: One VFR Flight Plan from KORF to TXKF; The other an IFR



Flight Plan from KLGA to TXKF with a departure time one hour before my ETA at TXKF. This way I would have an Instrument Flight Plan on file to pick up once I was able to contact NY Center –The flight plan had to leave from KLGA to get it in NY CTR’s system (KORF-KTXKF would have been in WASH CTR’s system).

The return trip is pretty much the same with a few wrinkles:

Wrinkle One: Bermuda requires an Instrument flight plan to leave Bermuda Airspace.

So I departed on an IFR Flight Plan, when tower handed me off to NY Center, I told them what I was doing, and that I would need to cancel my IFR flight plan and activate my VFR flight plan before I lost radio contact. They canceled me at about 50 miles out, and let me know when they lost radar contact. I switched from the assigned squawk to 2100, and then to 2000 crossing the 180 NM line . . . easy.

Wrinkle Two: Although I had given an ETA for the crossing into the ADIZ when I filed my DVFR

Flight Plan, a medevac flight that delayed my departure and head winds put me crossing in to the ADIZ more than 15 minutes off my scheduled crossing time. Fortunately, I was able to relay to center my new ETA, altitude, and location for crossing into the ADIZ.

Wrinkle three: I called US Customs before I departed Bermuda with what I thought was a reasonable ETA. When I got back into radio contact approaching the



US Coast, I asked ATC to let Customs know I was running behind schedule. They said they would, I gave them the phone number for the Norfolk Airport Satellite office, they said they had a different number they would call. To compound the confusion, ATC had a problem understanding my tail number and aircraft type, and when the fellows at Customs checked Flight aware, they could see my take off, but nothing else. They called my office, generating all kinds of upset. I apologized to everyone, took responsibility, apologized again, and everything was OK.

They checked the plane with a radiation detector, checked my Customs sticker, Form 178, and General Declaration, pilot's license and physical; it was quick and easy. They gave me some blank Gen Dec Forms for future times. The US Customs Aircraft Parking area is just to the right of the yellow DC-9 (Airborne?) Gate "D", they do not have a sign, and ground is not too familiar with exactly where to go.

The trip (the easy part):

The easiest origin and return destination is Norfolk, VA. Distance is about 660NM and customs is available on the field.

My route was KORF ORF AR9 ZIBUT UMEDA DASER TXKF

I chose this route because it kept me clear of the restricted area off VA beach, and staying on Atlantic Routes the entire way would have added a lot of unnecessary distance.

The regulations (North Atlantic General Aviation Operations Manual) require maintaining a trip log. They give instructions on how to prepare one.

For me, the big issues are:

Fuel Burn... how much, how fast? Am I burning more fuel than expected relative to distance and time? Is my ground speed faster

or slower than expected?

Where is the point of no return... on one engine?

I kept a running log of the time I crossed each intersection on my route, (I attempted to relay to ATC my crossing time for each intersection), and periodically I recorded my fuel used reading, and the time, the indicated fuel burn, and the TAS and GS.

From these numbers, I could calculate my fuel burn, and determine how I was doing relative to my plan.

My plane has Data link weather and on-board weather radar, the data link kept working all they way across, but the actual data was very limited, without ground radar, etc, all I received was cloud coverage, and that ended just short of Bermuda.

XM radio worked the entire way.

On-board radar was great, I could see the cells, and adjust my course to easily avoid them. Without radar, it would not have been possible to determine the best way through lines of squalls.

I doubt a storm scope would have been much help as there was very little lightening, just rain and wind.

Bermuda has a website that give Bermuda weather and radar images, and ADDS has Bermuda Aviation weather (past, current and forecast). Due to an afternoon forecast for temp weather below VFR minimums, I left very early in the morning; I had to check on official nautical twilight for to make sure I did not cross into Oceanic Airspace before daylight, I had to get close enough to ensure I would arrive in Bermuda before the



new forecast became effective. It worked out.

Most of the trip was spent monitoring the engines and watching for weather, I looked for jet trails, and ships. Nothing, until 50 miles out on my return, I saw two aircraft carriers. At 4,500' I could see individual waves and white caps, I kept imagining whales, or small boats, but, as I would watch, whatever I was seeing would fade away. The other factor going both ways was heat; at lower altitudes it was miserable until I depressurized the cabin to get more outside airflow. That worked. The outside air was 55-60 deg. F which wasn't bad as I was wearing shorts on my return.



Logistics (FUEL):

No AVGAS for sale in Bermuda.

I shipped two 55 gallon drums from Virginia to Bermuda.

It can be done, I purchased the drums and the HAZMET labels, filled the drums at a local airport, secured them to a pallet, and had them shipped to New Jersey. Bermuda Container Lines hauled them to Bermuda, and Bermuda Forwarders hauled them to Sovereign Flight Support. Cost for Shipping Approximately \$1,000.00.

Forrest Ward Biography

Forrest Ward flies a 1977 601P Aerostar. He began flying in 1983 during his senior year in College. He earned his commercial and instrument ratings while serving in US Marine Corps (1983-1987). From 1987-1991 Forrest lived in Alaska and flew multiple types of planes (C207, PA32, PA31, BE-1900).

From 1992 to 1998 he flew SF-340's & BE-1900's for a Delta affiliated Regional Airline (Business Express). In 1998, Forrest made a career change and started his own HVAC/R business, specializing in restaurants, and he says "I'm still in business.... 10 years later." Forrest Ward bought his Aerostar (N601PE) in May of 2007. He resides in Hampton, Virginia with his wife (Molly) and 2 sons (Edwin 14 & George 12).

And Don't Forget:

- Passport
- Bring twice as much money as you expect to spend
- Bring 1/2 the clothes (stuff).
- Camera would be nice

References:

Airmen's Information Manual (AIM)
AC 91-70 Oceanic Operation Authoritative Guide
The Air Navigation (Overseas Territories) Order 2007 (AN(OT)O) 2007
The North Atlantic General Aviation Operations Manual 3rd Edition

Points of Contact:

Forrest Ward
757-838-5400

Survival Products "Robert"
954-966-7329

U.S. Customs 757-858-6196
After Hours# 757-533-4218
757-858-6274 (FAX)

Freight from VA to NJ
ASF Transport Services
Alex Fino
215-779-6955

Bermuda Container Lines
WLG (USA) LLC
David Duke
224-653-2805

Bermuda Forwarders
Willie Forbes
441-292-4600

Sovereign Flight Support (TXKF)
Sheldon Steede
441-293-3892

ZANE PRITTS AVIATION INC.
EXPERTS ON THE INS AND OUTS OF THE AEROSTAR

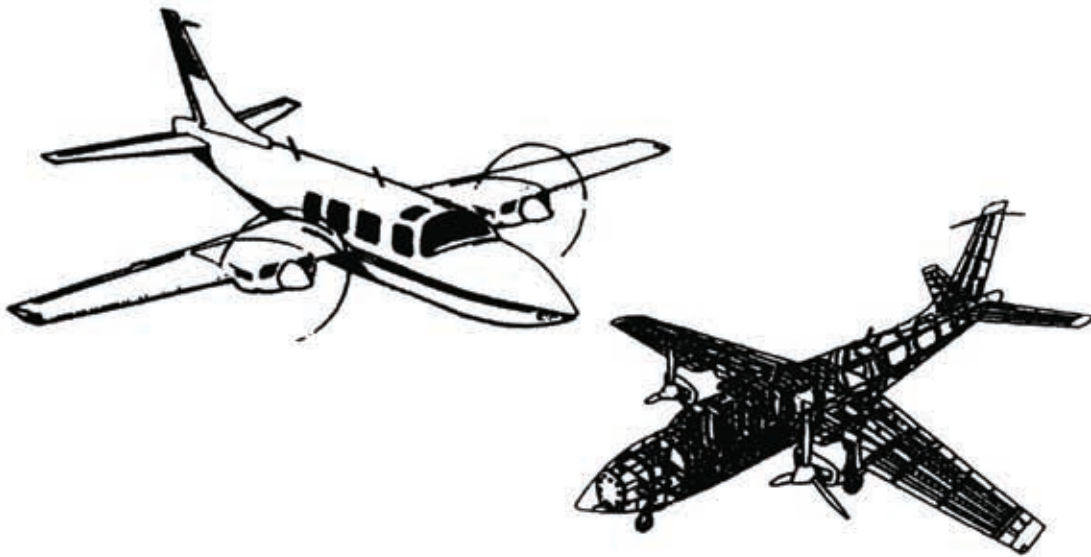

**EXPERT SERVICE AND QUALITY MAINTENANCE
FOR YOUR AEROSTAR IN A MINIMUM AMOUNT OF TIME**

44050 RUSSIA ROAD, ELYRIA, OHIO 44035

LORAIN COUNTY REGIONAL AIRPORT (LPR)

FAX: 440-322-5511

PHONE: 440-322-4945

"EZ GLIDE" Seat Anchors— *The Aerostar Solution*

- Seats Slide Easily — Lock in Place Every Time
- Seats Cannot Come Out of Tracks
- Use Existing Tracks

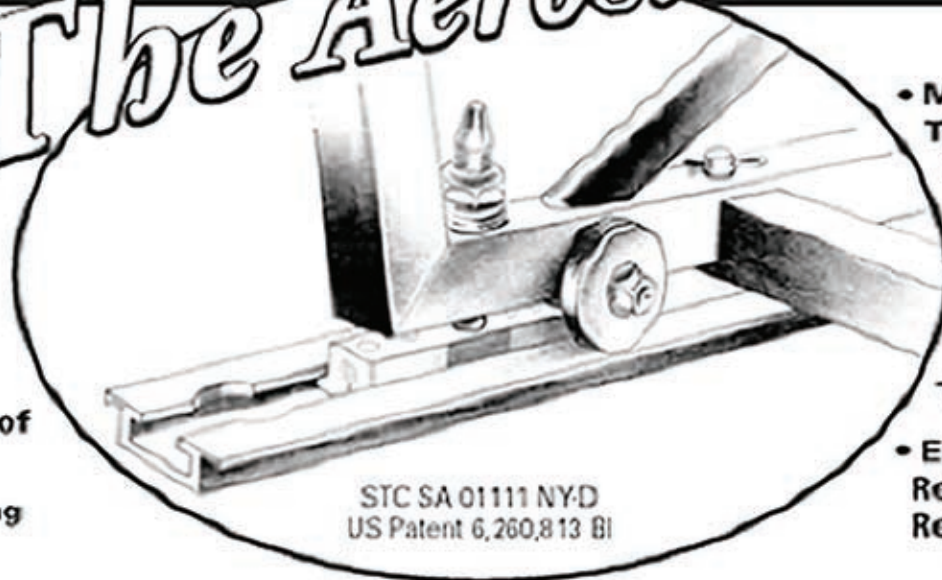

- More Than Twice as Strong
- Hi-Strength Alloy Steel
- Latest Plastic Technology
- Easy Seat Removal and Replacement

November Whiskey, Inc., 340 Water Street, Newport, Delaware 19804

For Information or to place an order **800-287-3841**

Telephone 302-993-0587 Fax 302-996-9318 email: jpwhitcomb@aol.com

KRUEGER AVIATION

FOR 5 ★ SERVICE, CALL ON KRUEGER AVIATION INC.

- ★ AEROSTAR SPECIALIST FOR OVER 25 YEARS
- ★ PRE-PURCHASE & MAINTENANCE CONSULTING
- ★ AVIONICS & CUSTOM INTERIORS
- ★ COMPLETE INSPECTIONS AND OVERHAULS
- ★ MODIFICATION & REFURBISHING

KRUEGER AVIATION INC.
ERIC KRUEGER -Owner
1421 SKYHARBOR DR
YUBA COUNTY AIRPORT
OLIVEHURST, CA 95961
(530) 743-7040
(530) 743-1920 FAX
WWW.KRUEGER.AERO
ERIC@KRUEGER.AERO

What's Your

By Ken Bacon



The Aerostar 600A.

h Mission?



I'm so glad to see the continued interest in the Aerostar almost 40 years after the first 600 rolled out of Ted Smith Aerostar Aircraft Company. Today's interest is a tribute to his expertise in the aviation community.

Our AOA membership changes and grows due to new members who would like to own THE WORLD'S FASTEST PISTON TWIN. The conversation with our new members always turns to "Which Aerostar model is right for me?" I answer their question with a question "What's your mission?" Tell me about what you currently fly and where do you usually go, and how many passengers do you carry.

In an attempt to help AOA members and future members as well as current Aerostar Owners, I would like give you my opinion on the different Aerostar Models and their benefits. So here goes, please don't get your feelings hurt.

The first production model to roll out of Ted Smith Aerostar Company was the 600. The early models of the 600 didn't have zinc chromate coating on all aluminum parts which later resulted in possible corrosion issues. This problem went away when Ted bought the company back from Butler Aviation in the 1974 model year. The 600's have a light duty crankcase which is susceptible to cracking between cylinders. It is repairable and many have been welded or replaced with heavier crankcases. The good news is the 600 is a 200 knot aircraft which can operate on 30 GPH or less fuel. Also, it is the least expensive to maintain. It has great range but is limited to 5500 lbs. gross wt. I have only heard of one with Known Ice, but the option can be added. The service ceiling is 20K feet but most owners operate them below 14K. Finding a low time 600 is very difficult because they were very popular as freight haulers.

The next model to come from Ted was the 601; they date back to 1969 and became the 601A in 1974 with an engine change. This is one of my favorite models due to its 30K foot service ceiling. It tends to fly a little nose high in the flight levels but it is light weight and turbocharged, which equates to fast. I have flown in a 1970 601 with intercoolers @ 27K feet true airspeed was 257 knots burning 32 GPH.



Jimmy Mullen's 601P

The early 601's used a Lycoming Engine which had a 1400 Hour TBO and had the same corrosion issues as the early 600. The 601A changed to the old reliable IO540S1A5 which was also used in the 601B and 601P. Both 601 and 601A had electric motor driven wastegates which are simple to repair and simple to operate. Another great thing about the 601 is you can operate it with the turbo on or off, your choice. Due to Ted's utilization of the STC process for many of his turbocharger add-ons, you

"The 601P was the longest production run and the most numerous model existing today."

may find a 601 out there which has had the turbos removed via another STC. The early 600 and 601's used a Bendix 810 Autopilot which is very hard to find parts for. Autopilot Central still works on them but parts are limited. I see many modernized Aerostars updated to the Stec Autopilot.

After Ted purchased the Aerostar back from Butler he developed the pressurized model 601P. The first models (1974) were STC conversions of the 601A with wing extensions and the Lycoming IO540S1A5 Engines. The service ceiling was limited to 25K feet most likely due to the 4.25 lbs./sq. inch pressurization system which held an 11K foot cabin @ 25K feet. The 601P was the longest production run and the most numerous model existing today. In 1978, after Ted's death, Piper Aircraft Corporation bought the Aerostar rights from Ron Smith (Ted's Son) and Ted's widow. The production was later moved to Vero Beach, FL. Under Piper's ownership the 601P got heavier, but the ventilation system was greatly improved. The fuel burn of the P-model runs 34-36 GPH @ 65% power. Additionally, Piper changed the Turbochargers from the RayJay part no. 600574 to the 600575. This change improved the altitude capability of the p-model Aerostar. The majority of the Ted Smith 601P Aerostars used the EDO Mitchell Century IV Autopilot and the Piper version used the King KFC-200.

The Ozone landing gear was used on the early 600, 601, and 601P models until Ozone went broke around

1978. With the Piper 1979 model year the Weibel landing gear was utilized until the end of production 1985.

The gross weight of the 601P and the 601B is 6000 lbs. Oh yes, in 1976 Ted introduced the 601B, which has the wing extensions and the wastegate actuator system of the 601P but is not pressurized. There were very few built but what a pay load. Empty the 601B weight is approximately 4100 lbs. and will carry approximately 1900 lbs. of pay load burning 32 GPH. Put the Machen Aux. Fuel Tank in this Aerostar and fly 1200 NM non-stop. Top it off with a service ceiling 30K feet.

In 1980 Piper decided the 601P did not have the power it needed for single engine safe operation, so they changed the Lycoming Engine from the S1A5

to the IO540AA1A5. This engine change created the 602P. The AA1A5 was rated at 260HP with the low compression engine (7.3:1) versus 290HP S1A5 (8.7:1). Therefore the 602P needed more powerful turbochargers to provide the 37 inch boost necessary to provide the 290HP. Piper also added Known Ice to the 602P model. The fuel burn increased due to the low compression motors to approximately 40 GPH. Due to Piper's desire to create a perfect Aerostar, the 602P had a short production life (1980 thru 1983).

Since the initial purchase of the Aerostar, Piper was never happy with the manufacturing methods and parts count for construction of the Aerostar. But, every model of the Aerostar which Piper built took longer to make and required more parts than the Ted Smith Aerostar. Piper had several years experience fixing under warranty Aerostars, which they thought would help them create the perfect Aerostar.

So in 1984, they built what they believed was the perfect Aerostar. They produced twenty-five (25) model 700P Aerostars in their last year of Aerostar production. Yes, they did fix a lot of the issues like single engine service ceiling, weight and balance, and better cylinder cooling. What they didn't improve was a higher service ceiling, a significant gross weight increase, and a pressurization system increase.

The 700P utilizes the Lycoming TIO540U2A Engines which are low compression 350HP Turbocharged/Intercooled. In my opinion these engines are the best engines Lycoming has produced to date. The crankcases have all the fixes to the design which have caused failure in the previous high horsepower models. They come





Kurt & Carolyn Langseth's 602P

from the factory with pressurized magnetos and the heaviest crankshaft. The problem Piper and Machen (talk about them later) had with the 350HP motors is controlling the high cylinder head temperatures. Piper solved this problem with engine cowl flaps. The 700P POH calls for opening the cowl flaps during take-off and climb. During the summer months the cowl flaps will need to be opened slightly during cruise when operating a 65% power in order to keep the cylinder head temps at or below 400 degrees F.

The 700P single engine service ceiling is the highest of all the models at 15K feet and the best reason for the 700P is the rate of climb on one engine at gross weight. The Aerostar will climb 350 feet per minute from sea level on one engine with flaps up, gear up.

The weight and balance had to be improved due to the additional fuel which you must carry to feed these big motors. The fuel burn at 65% power is 45GPH. The way Piper improved the weight and balance was move the aux. hydraulic pump into the nose and the battery from the tail to just behind the luggage compartment. With the 700P full of fuel (approx. 220 gal.) the pilot and co-pilot seats need to be occupied to keep the aircraft in the CG Envelope.

By turning the right engine propeller right and the

left engine propeller left they reduced the engine noise in the cabin as well as convincing the FAA the aircraft does not need vortex generators or the water rudder for low speed enhancement. But by doing the engine thing the 700P ended up with two critical engines instead of one.

Speaking of the water rudder, this was Piper's answer to low speed handling issues which the FAA was not happy with in the early 1980's. The one nice thing about the water rudder is an improvement in crosswind landings. One of our AOA members has landed his 600 with the rudder in a 36 knot direct crosswind. He says without the rudder it would not be possible.

Even though the 700P is the heaviest of all the Aerostars produced it is cleanest of all the 700 HP models due to Piper mounting the intercooler aft of each engine to reduce the drag of the air intake of the intercooler. The back of the engine of the 700P is harder to work on due to the location of the intercooler. Well everything in aviation is a trade off!

In the early 1980's Machen Aircraft Corporation comes on the scene with after-market modifications for the Aerostar. The owners of Machen, Jim Christy and Steve Spears, have produced many STC's

and additional products for the Aerostar along with several power plant enhancements.

Before Machen modified the Aerostar they were modifying Bonanzas with Navajo Engines. So, naturally the Superstar II which did away with the lighter cased S1A5 engines for the Lycoming TIO540J2BD engines of the Piper Navajo Chieftain. Well, this is probably the fastest Aerostar ever created. But, speed in aviation does not come without a trade off. The single turbocharger of the J2BD engine cooks the accessories on the back of the engines; as well as the single drive dual magneto, which has been plagued with problems over the years. In my opinion, the maintenance on this aircraft is out of control. Another issue is the tight cowling of the Aerostar and the up-draft exhaust system. The TBO of this engine is 1400 hours and costs \$50K to overhaul. This installation runs hot no matter how you operate it. But, if you are hell bent on owning one of these speedsters then you need to know Eric Krueger @ Krueger Aviation in Olivehurst, CA. Eric is the Superstar II expert and has developed several STC's for the Superstar II to help reduce the cost of ownership.

The 2nd power enhancement was the Superstar I which took the IO540S1A5 (290Hp) engine of the 601P and increased the power to 325HP per engine with low compression pistons and higher volume turbochargers. The manifold pressure increased to 42 inches. Additionally, they added intercoolers and low noise propellers to produce the 700 HP. By increasing the power of these Lycoming motors the internal pressures increased and case cracking increased in the old design crankcases.

The 602P was easier to convert to a Superstar 700 because the AA1A5 engines had a newer stronger case and already had low compression pistons. By changing the turbochargers, adding low noise propellers, and intercoolers "Voila" 700HP. As I said before Piper didn't make many 602Ps, so the candidates for this enhancement were limited.

Machen was very successful in marketing the Superstar Program due to the increase in safety related to single engine rate of climb @ take off and

single engine service ceiling increase. Due to the heat created by the higher horsepower engines the speed in cruise is approximately 8 to 10 knots over the 601P and 4 to 5 knots over the stock 602P. So in 4 hours of flight the Superstar 700 is no more than 40 NM ahead of a 601P. The 700 is burning 45GPH the 601P is burning 36GPH.

Many of the Machen Products can be added to any of the models, such as the low speed enhancement mod (vortex generators) which satisfies an AD or the aux. hydraulic pump. By the way, I would not fly an Aerostar without the Aux. Hydraulic Pump due to the possibility of losing the right engine on take-off and needing to raise the gear and flaps.

My favorite modifications are the intercoolers, short propellers, six puck brakes, and oil breather separator system. Known Ice enhancement is available for all models but is stock on the 602P and the 700P.

In my opinion the Machen Aux. Fuel Tank is a better system than the Nyak System of the Piper 700P. The Nyak System is automatic which means you turn it on or off but fuel only transfers when the level in the fuselage tank is below 30 gals. The Machen System is automatic or manual. In the manual mode you can transfer fuel to the fuselage tank filling it above the main tank filler cap (approx. 18 gals more fuel).

The Machen exhaust system is also a nice enhancement to have on your Aerostar. The system is made of inconel and can handle the higher exhaust temperatures better than the original stainless steel. Additionally, the Machen inconel tail pipes do away with the every 50 hour inspection of the stainless steel tail pipes. This system is not available on the Superstar II.

"The 602P was easier to convert to a Superstar 700 because the AA1A5 engines had a newer stronger case and already had low compression pistons."



Jerry & Vonda Gardner's 700P

Well, now we have covered the history and all the different models. Which one is right for you? Again, "What's your mission?" You have to ask yourself some questions and answer them honestly.

1. Where do I usually fly?
(mountainous areas or flat lands)
2. How many passengers do I usually carry? *(my wife and a suit case or 5 hunters and their gear)*
3. How far do I usually fly?
(400NM or less / 800NM to 1000NM)
4. Do I fly in all weather conditions?
(Known Ice or NEXRAD/on board Radar)
5. How many hours annually?
(200 or less, more than 200 per year)
6. What model can I get Insurance on?
(non turbocharged, or pressurized)
7. How much can I afford to spend on maintenance? *(600 normally the least expensive to maintain)*

Okay, if you want to fly 800NM or greater with 3 or four passengers on-board then you need to get a 700. If you are a flatlander or an islander you can get a good ride with the 600 or a 601. If travel means you and your spouse with a suit case, a 601P or a 602P is just what you need.

Whatever you decide remember to get a pre-buy inspection from one our Aerostar Maintenance Facilities. I can't count the number of horror stories I have heard or witnessed firsthand when the pre-buy was performed by the seller or seller's maintenance provider. Also, take this bird up to altitude! Don't just fly it around the pattern and buy it. If it is p-model then up to 25K, check the pressurization and the engines ability to perform.

Just one more point, the majority of the Aerostars out there FOR SALE have been setting in their owners hanger for several years before the owner agrees to sell them. You will understand this once you become an owner. Most Aerostar owners believe their Aerostar is part of the family, so it is a sad day when they agree to sell it. Their love for their Aerostar creates initial maintenance opportunities once you start flying your newly purchased Aerostar. So, as a rule of thumb you will spend about two years fixing all the little things that didn't store well and were not found during the pre-buy inspection.

If you have questions or need assistance please contact us, we will help you find the support you need flying, maintaining and even shopping for the Aerostar of your dreams.

Fly Safe!

Ken

AEROSTARS

Model Comparison Chart

	600/600A	601/601A	601B/601P	602P	700P
Price when new	\$93,500 to \$324,000	\$112,500 to \$164,900	\$186,000 to \$323,760	\$333,500 to \$408,890	\$499,300 to \$514,280
Specifications					
Powerplants	2 Lyc. IO-540-G1B5 (600) 2 Lyc. IO-540-K1F5 (600A)	2 Lyc. IO-540-P1A5 (601) 2 Lyc. IO-540-S1A5 (601A)	2 Lyc. IO-540-S1A5	2 Lyc. IO-540-AA1A5	2 Lyc. TIO-540-U2A
Recommended TBO (hrs)	290 hp @ 2,575 rpm (G1B5) 1,400 (600) (K1F5) 2,000 (600A)	290 hp @ 2,575 rpm (P1A5) 1,400 (601) (S1A5) 2,000 (601A)	290 hp @ 2,575 rpm (S1A5) 1,800	290 hp @ 2,425 rpm (AA1A5) 1,800	350 hp @ 2,500 rpm (U2A) 1,800
Turbochargers Part No. (2)	NA	600532-01/02	Low Alt 600574-01/02 High Alt 600575-01/02	600626-01/02	600803-01/02
Propellers	2 Hartzell full-feathering 3-blade, 78 in dia	2 Hartzell full-feathering 3-blade, 78 in dia	2 Hartzell full-feathering 3-blade, 78 in dia	2 Hartzell full-feathering 3-blade, 78 in dia	2 Hartzell full-feathering 3-blade, 76 in dia
Recommended TBO (hrs)	1,500 (or 4 yr)	1,500 (or 4 yr)	1,500 (or 4 yr)	1,500 (or 4 yr)	1,500 (or 4 yr)
Length (ft)	34.8	34.8	34.8	34.8	34.8
Height (ft)	12.1	12.1	12.1	12.1	12.1
Wingspan (ft)	34.2	34.2	36.7	36.7	36.7
Wing area (sq ft)	170	170	178	178	178
Wing loading (lb/sq ft)	32.4	33.5	33.7	33.7	35.4
Power loading (lb/hp)	9.5	9.8	10.3	10.3	9.02
Seats	6	6	6	6	6
Cabin length (ft)	12.5	12.5	12.5	12.5	12.5
Cabin width (ft)	3.8	3.8	3.8	3.8	3.8
Cabin height (ft)	4	4	4	4	4
Max ramp weight (lb)	5,525	5,700	6,025	6,029	6,356
Max takeoff weight (lb)	5,500	5,700	6,000	6,000	6,315
Max landing weight (lb)	5,500	5,700	6,000	6,000	6,000
Zero fuel weight (lb)	5,400	NA	5,900	5,900	6,050
Empty weight (lb)	3,560	3,730	4,000	4,125	4,221
Max useful load (lb)	1,965	1,970	2,025	1,904	2,135
Payload w/full fuel (lb)	972	977	1,032	911	1,142
Fuel capacity (lbs/gal)	1,041/173.5	1,041/173.5	1,041/173.5	1,041/173.5	1,281/213.5
Fuel capacity-useable (lbs/gal)	993/165.5	993/165.5	993/165.5	993/165.5	1,233/205.5
Baggage capacity (lb/cu ft)	240/30	240/30	240/30	240/30	240/30
Performance					
Takeoff roll (ft)	1,550	1,645	1,900	1,800	1,950
Accelerate/stop (ft)	3,050	3,145	3,490	3,400	4,000
Rate of climb (fpm)	1,800	1,800	1,970	1,755	1,820
Single-engine ROC (fpm)	360	380	254	302	320
Cruise speed (KTAS)	211/	237/	233/	229/	258/
Fuel consumption (gph)	33	29	36	37	51
@ power setting/altitude (ft)	70%/7,500	70%/20,000	74%/20,000	75%/20,000	81%/25,000
Max operating altitude (ft)	21,200	30,000	30,000(601B) 25,000(601P)	25,000	25,000
Single-engine svc ceiling (ft)	6,300	10,800	9,300	12,900	14,900
Landing roll (ft)	1,200	1,230	1,230	1,217	1,425
Limiting and Recommended Airspeeds (KIAS)					
Vmc (min control w/critical engine inoperative)	84	84	84	84	85
Vx (best angle of climb)	100	100	100	101	101
Vy (best rate of climb)	122	122	117	117	116
Vyse (best single-engine ROC)	113	113	109	117	116
Va (design maneuvering)	162	162	166	166	160
Vfe (max flap extended)	148	148	148	148	148
extend/retract	156/NA	156/NA	156/130	156/130	153/140
Vno (max structural cruising)	215	215	215	215	215
Vne (never exceed)	241	241	241	241	244
Vs1 (stall clean)	83	83	86	86	75
Vso (stall in landing configuration)	74	74	77	77	71

Figures based on standard day, standard atmosphere, sea level, gross weight conditions, unless otherwise noted

WHAT ABOUT THOSE LYC

By Ken Bacon



DivCo Corporate Offices (Tulsa, OK)

Over the years I have heard lots of Aerostar Experts talk about the differences in the Lycoming Crankcases. They would tell us the new cases are better than the older cases. Well, that would make sense in that you would expect Lycoming

to continue creating a better design as the years race on. But, is it true? I decided to go visit with a Tulsa, OK based crankcase repair facility named DivCo, Inc.

DivCo, Inc. began 1976 as a machine shop specializing in aircraft cylinder and crankcase repair. However, when Lycoming started providing new cylinders as cheap as you could repair them, well that spelled the end of the cylinder business. Today, DivCo is known world-wide as a leader in crankcase repair. DivCo was founded by Charles Jarvis and his wife Sandy who continue to manage the company today. I met with Chuck Jarvis (their son) and DivCo General Manager for a plant tour and Q&A about Lycoming Crankcases.

I shared with Chuck some of the things I had heard about Lycoming crankcases over the years. Such as the higher part number crankcases are better than the older low number cases. His response was "Yes, the newer cases are sometimes better but there's no guarantee. Let me show you a few cases we have in for repair and some that can't be repaired."

As we walked into the plant I could tell very quickly many of the people who work here are long time employees and are proud of what they do. The first case he showed me was a

1st run latest modification (LW-18542 series) case with a red tag (not airworthy) hanging on it. When cases come in they are immediately tested for hardness and thickness. The test results showed this case was too thin and too soft. How could this happen? Well, the softness was heat treating and the thickness was a casting problem. Chuck says "This is not the norm but does occur from time to time even in the latest production cases. In this case you can see the softness in the excessive wear of the bolt holes."

The next case we looked at was an older case (LW-13827) and from the stamped marks on the case edge you could tell this was its second visit to DivCo. They found no cracks in the case or fretting (I will explain fretting later). The cases in



3. LW-13827 Older Series (Circa 1977) 2nd Time to DivCo



4. Lyc. Case with 8hrs. SOH, connecting rod bolts came lose and rod came thru case



5. Lyc. Case with thru-hole sleeves

my 601P are LW-13827's. You can definitely tell the ribs between the cylinders are much thinner than the newer case we examined. Most of the cracks in the case occur between the cylinders or the area below the cylinder opening.

I ask Chuck how many welders work at DivCo? He answered one welder who has been with us 19 years. Most of our 22 employees are machinists and a couple of our employ-



1. LW-18542 Heavy case (New Series) too soft/too thin

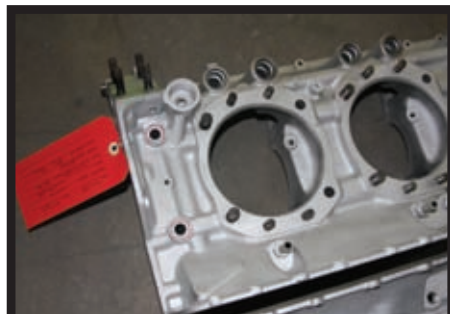

2. LW-18542 Holes warn (due to soft case) Notice red circles

COMING CRANKCASES?



6. Lyc. Case with thru-bolts & hole sleeves



7. Lyc. Case welded between cyls. Typical cracking area between cyls.



8. Latest series case (Notice heavier webbing between cyls.)

ees have been with us for over twenty years. The secret to the DivCo success is in the heat treating of the cases which they call heat normalizing. Since DivCo inception they have processed some 90,000 crankcase.

The next case Chuck showed me was a 14 hour crankcase where the rod bolts came loose and the rod was thrown, and yes they believe they can repair it. They weld it and inspect it to see whether or not it can be machined successfully. Chuck says we always try to save the customers case because we know how expensive they are to replace (approx. \$15K).

Chuck believes the major reason the crankcases crack is fretting. Fretting occurs when the mating surfaces or thru-hole posts vibrate against each other and change the dimensions of both parts in small areas. Almost all cases which come to DivCo have some form of fretting. To minimize the fretting the case needs periodic re-torquing of case and cylinder bolts.

Lycoming addressed the fretting problem by thru-hole post collars (SB-1123). These collars must be machined into the case halves. Per customer request in most situations DivCo will install the collars at no additional cost. Currently, DivCo charges a flat rate of \$855.00 for a six cylinder Lycoming case no matter how much welding and machining is required.

It is great to know someone out there is trying hard to help us keep our Aerostars flying and at a reasonable cost. You can visit DivCo, Inc. website @ www.divcoinc.com Fly Safe!

Ken

AOA EXECUTIVE DIRECTOR



9. Latest series case (Notice additional bolt hole on lower row.) Older cases have 2 holes not 3



10. Lyc. Engine Case "Fretting" example



11. Lyc. Engine Case "Fretting" example

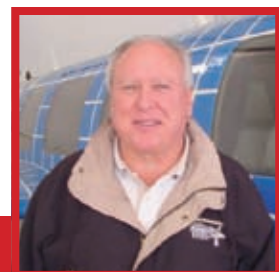

What's in My Crystal Ball?

Thomas H. Chappell

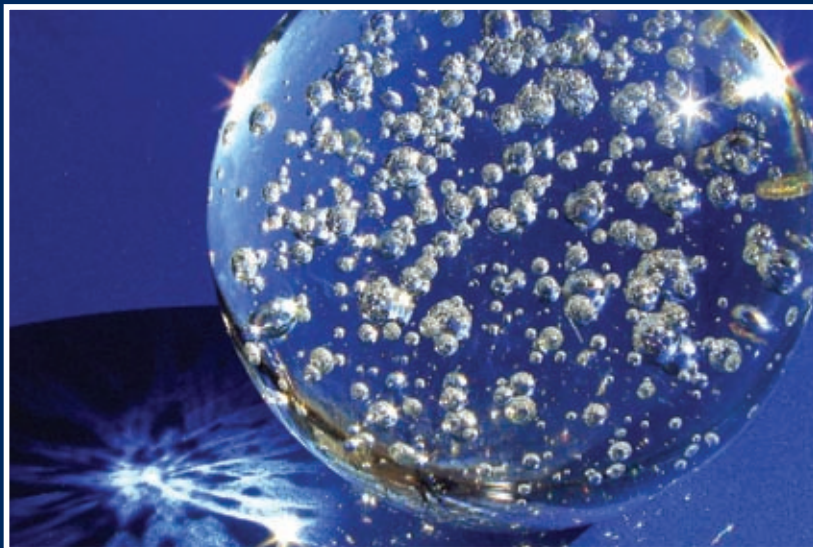

The insurance market has endured declining premiums for several years. I have written about the soft market conditions on a number of occasions. Obviously, the insurance consumer is pleased to see the soft market and its reduced premiums and the insurance companies can't wait until premiums return to normal and a time they can

"It has been my experience that the longer the underwriters endure a down market, the longer the following hard market cycle will be."

stop bleeding red ink. It has been my experience that the longer the underwriters

endure a down market, the longer the following hard market cycle will be.

What goes up must come down and vice versa. It is usually the new underwriting facilities — those underwriters that enter the industry trying to buy market share with cheap premiums — that cause the imbalance between affordable insurance

premiums and reasonable profitability for the underwriting company. In a market sector as small as aviation, just one new player (underwriter) can upset a balanced market with overcapacity, forcing rates down. But, that is capitalism; the survival of the fittest.

We are nearing the end of the third quarter of 2008. I receive many phone calls each week from both consumer and underwriter alike wanting to know my opinion of where the insurance market is in the cycle. When will we see a market change? I read and study, discuss the topic with industry leaders, and come back to one answer. It is anybody's guess at this time.

Because insurance is such a large line-item expense for many of our clients, this answer is very important in their planning and budgeting process. I do not claim to have magical insight. I can tell you that I have done my research and will give you the benefit of that and my best guess. This research will include both aviation industry intelligence as well as information affecting the general property and casualty sector. Unlike most market moves of the past, in this cycle, the property and casualty insurance sector is cycling with the aviation insurance market.



One of the most respected publications in the insurance world is National Underwriter. In the July 28, 2008, issue, an article appeared with the title "Declines Slowing — Property-Casualty Prices Show Signs of Stability in Second Quarter." This article explains that the soft market premium inadequacy coupled with the recessionary economy is beginning to have a negative effect on insurance company bottom lines. The one bright spot for the insurance companies over the past two years is the mild hurricane season. Recent surveys of insurance brokerage firms report that the pace of price declines is leveling off.

Reports out of London reveal that many of the reinsurance syndicates and underwriting companies are seeing declines in profits. The Insurance Insider reported that "Catlin Group Ltd's pre-tax profits fell by \$40 million in the first half of 2008." Although still profitable, an industry leader such as Catlin is unaccustomed to sliding profitability. Some of this performance is more the result of poor investment returns than underwriting losses. The downward trend can still affect an underwriter's enthusiasm for aggressive pricing when quoting insurance. According to the Aug. 8 issue of the Wall Street Journal, Catlin Group Ltd was not alone in its diminished profits. Allianz, Europe's largest insurance underwriter, reported a 28 percent decrease in profits in the second quarter. Axa, the second largest insurer in Europe, showed a decline in profits of 32 percent.

And it doesn't end there. According to The Associated Press, Berkshire Hathaway Inc. posted a decline of 8 percent in profits for the first quarter of 2008.

Like Catlin, the profit shrinkage with the other leaders of the insurance industry is not totally the result of underwriting losses but poor investment performance, as well.

In addition to poor second quarter performance in the profit and loss sector, the values of the stock of those companies that are publically traded have been pulled down, in part, because of the bad news about American International Group (AIG).

Add all this turmoil up and the result may indicate that the end of a soft market is near and the firming of insurance cost may be just around the corner. I cannot tell you in months, days, or hours when the market will turn. All indications would make me think that renewal rates would be flat by the end of the first quarter of 2009. We may see slight increases in renewals by the end of 2009 with significant increases in 2010. This trend could be altered, however, if we have an improvement of investment returns that will take some of the pressure off of underwriting performance, extending the buyer's market. Of course, a catastrophic event like Sept. 11 could throw us into an immediate hard market.





BRING YOUR AEROSTAR INTO THE 21ST CENTURY!

Plastech's Pleated Shade Window Kit will bring your Aerostar's interior up to speed with the rest of your airplane. Shades extend to block light and radiant heat or neatly retract out of sight. Altogether replaces yellowed, warped or cracked interior panels.

CALL US AT 404-355-9682 FOR A COMPLETE LIST OF COMPONENTS AND PRICES OR VISIT US AT WWW.PLASTECH.COM.

- ◆ *Modern Styling*
- ◆ *Easy to Install*
- ◆ *More Window View*
- ◆ *Replaces Old Yellowing Plastic*
- ◆ *New Inner Windows Included*



2080 GENERAL TRUMAN STREET, N.W. • ATLANTA, GEORGIA 30318

PHONE: 404-355-9682

FAX: 404-355-5410

EMAIL: INFO@PLASTECH.COM • WEB SITE: WWW.PLASTECH.COM

ICE MAINTENANCE

COMETH

By Lester Kyle

The season is upon us again when icing to structure and engines of our machines becomes more of a daily occurrence. It's always somewhat present even in mid-summer at the altitudes we fly.



It's a proven fact that the majority of icing occurs between 3,000 to 6,000 feet AGL. It's also a proven fact that 80% of icing accidents occur during the approach segment to an airport

The primary cause for these accidents is making the approach at the normal airspeed instead of an extra 15 knots. The use of full flaps is certainly not recommended. It's far safer to slide off the far end of the runway under control than to come up short, which usually is due to a stall condition at a very low altitude.

Two things must be accomplished to prevent this. The pilot must be prepared and equally the aircraft should have fully functional de-ice equipment. If you do not have the approval for flight into known icing, it's important to know that what you do have is operational. Do the boots function as necessary and were they treated just before flight with Ice-X to keep them slick to prevent possible ice build-up?

Does the prop heat stay in the green arc for two minutes? (Three minutes on Piper 700P.) An unbalanced prop can do terrible things. Does the pitot heat work? Don't forget the static source is also on the pitot tube; if it fails we lose three instruments, unless we know how to turn on the alternate static source. (Does that still work?)

Many Aerostars do not have the induction screens to help prevent possible ice. This is a good, inexpensive investment even if you don't have icing approval. Do you have the moisture deflector on the pneumatic air filter? This is another inexpensive investment.

"IT'S A PROVEN FACT THAT THE MAJORITY OF ICING OCCURS BETWEEN 3,000 TO 6,000 FEET AGL."

Should icing occur at a higher altitude (possibly causing an engine malfunction), be extremely cautious before enriching the mixture as it may already be too rich and cause the engine to fail. This is extremely important for the Factory Piper 700P because the EGT will indicate extremely high which is a false indication. The engines are actually running too rich and burning excess fuel in the exhaust pipe.

Fly'm High! Keep'm Dry!



AOA FOURTH ANNUAL MEETING



Looking Back to Future - Part III

This is the fourth AOA Convention which is being held in the brand new Aerostar Plant in Santa Maria, CA. The date is May 1974.

Excerpts from the November 1974 Aerostar Log.

Ted Smith reports that he is turning out a solid five to six airplanes a month, and they have made a few changes that are being extremely well accepted by customers. All production models now have the Cleveland wheel and brakes system, and reports are that they have been remarkably trouble-free. Also, all models now have pneumatic systems powered by dual pumps for the directional gyro and artificial horizon.

Boyd Lydick, formerly the popular Chief Engineering Test Pilot for Ted Smith aircraft, has been promoted to Vice President in charge of Marketing and customer service. Boyd urges all Aerostar owners to more extensively utilize field service reports.

TED SMITH: Welcome to the Aerostar Owners Association meeting. I was talking to Tom Fifield, and he recollects that this is the fourth meeting of the Association. My own recollection is that there have been four official meetings and one organizational meeting which makes this the fifth since the group got together. I might say that since we have taken the Aerostar back and got it on its feet again, tremendous progress has been made in getting this bird back into production. The interest in the Aerostar today is greater than it ever has been since the first one was delivered in 1968. The interest seems to keep building and building. I sit in my office and get calls daily from all over the world. Just before I left for a short vacation here a couple of weeks ago, I took calls from Australia, from New Zealand, from Brazil, from England and from Spain. Spain was interested in obtaining 25 Aerostars to put in their operation as military trainers. Unfortunately we are not in a position, even now, to fulfill orders such as this. It would be very nice if we could supply the demand that exists for the airplane.

Ron has done a tremendous job in bringing this organization together, and gradually we are building to a higher rate of production as each month goes by. Ron told me the other day that we are turning out six airplanes per month which is about what we expected for this period of time. We are not yet delivering six airplanes per month, since we have to get the pipeline full. We can't tell you at this time how many Aerostars we will build in 1975, but it will be a substantially greater number than we are building in 1974.

We have just completed the production certification of the pressurized version, the Aerostar 601-P. We had earlier certified and delivered several retrofitted pressurized airplanes which had a pressure differential of three pounds. The production 601-P has been increased to 4.25 pounds. Now what does this mean in flying at altitude? It means that at 25,000 feet where the airplane cruises at phenomenal speeds comparable to other aircraft in its class, you can maintain an 11 000-foot cabin and be cruising at something like 280 miles per hour, which in most cases surpasses the turboprop aircraft.

Getting on now to the future and what we plan for the Aerostar, for many years there has been a void



in the marketplace for a small jet aircraft — not the million dollar class — but something that a company that can afford to buy a turboprop airplane can also afford to buy in the jet area. We have committed ourselves internally to start on the Aerostar Jet Program in August or September of this year. We will have to take it a step at a time, but we will have one of the finest small jet airplanes that has ever existed. We plan on having an airplane that will stay below 30,000 feet for cruise and that will not be certified above 30,000 feet for a number of reasons, one of them being single pilot approval. Just yesterday I had a talk with Dick Schleft of the FAA. He is chief of the L.A. Region. He said that he didn't know just how much chance we had of certifying a jet aircraft for single pilot operation, but that it was worth trying to see if it could be done. He brought up the difference in speed between the Aerostar as it is today and the speed of the jet, and that there would be approximately 125 to 150 miles per hour difference. No one can tell me that difference in speed is going to make the difference between obtaining single pilot approval and forcing us into two pilot approval. We are going to do our very best to get single pilot approval for this jet aircraft.

I don't know how many of the members here would be interested in that type of aircraft for their own use, but it would open up an area in the marketplace that does not exist, and again we hope that Aerostar will be the first in this field. There is a precedent for single pilot approval for jet aircraft which is a number of years old. That is the Morane-Saulnier, a fine little airplane that was certified to 30,000 feet and was single pilot approved. So we would not be pioneering single pilot approval as such. There is a precedent on the books of the FAA.

Some of you may ask why not turboprops on the Aerostar. We just cannot see turning propellers with a jet engine. You have much the same problems that you have with reciprocating engines. You are still turning propellers, you still have the noise, you still have the maintenance of the engine and propellers, and you still have the inherent problems of driving an aircraft with a

propeller rather than a fan jet which is extremely inefficient.

We have been considering two jet engines. One that I am extremely impressed with ever since I saw it four years ago in France, is the Turbomeca Astafan. It has ratings from 1200 pounds on up to 2,000 or better in various models. The engine is about 20 inches in diameter and has an entirely new concept as far as the fan is concerned. It is a patented concept by Mr. Szydlowski who owns Turbomeca. The engine runs at constant speed and constant temperature, and the thrust is varied by the fan blades themselves which are governed for speed and angle the same way you govern your propellers on your Aerostar. It also is capable of a negative one degree angle on the blade which in effect can kill all the residual thrust from the engine and obtain a certain amount of reverse thrust. Even in flight you can use it as a slow-down device.

The concern that we have is that you don't start with a new airplane and a new engine together. We really are not starting with a new airplane but we are starting with a different version of the Aerostar which is a prototype of what will be the jet version. You have probably seen it at the airport today. If you have not seen it, please take a look at it. It is a miniaturized version of what the jet Aerostar will be. There will be other modifications beyond what you see.

The other engine, which I think we will have no choice but to use in the first go around, is the same engine that powers the Cessna Citation and some few other jet aircraft. It is fan-jet-powered and is the JD-15-D built by Pratt and Whitney. It is a larger diameter engine, perhaps a little heavier, but the economy of operation is quite similar to the Astafan.

The Astafan engine which I had the pleasure of flying in Europe three years ago, was installed on a Grand Commander by two pylons hung below the nacelles. So far, however, they have not certified this engine, either in Europe or in the United States, and since we have made the decision to move forward on this program, I see no alternative at this time but to go to the JD-15-D. Nevertheless, I plan, if able, to visit Mr.



Szydlowski in France later in May and see just what the status of the engine is.

Going on to more current things, I think that most of you today saw, perhaps for the first time, what makes an Aerostar. I am not sure if there was a wing available that you could look inside of, but you could see the components come together into one piece and then go on to the final assembly at the hangar to make it a complete airplane. I believe that you plan to visit more of the final assembly area this afternoon. There are many things that have to go into that airplane after it reaches the hangar, the engine installations, the propellers, landing gear, radio installation, optional equipment such as autopilots and boots in some cases. To be perfectly honest, I wish we didn't have a thing to do with optional equipment. We hope that one day this will be the responsibility of our dealer organization. We're not in business to build custom airplanes or to maintain airplanes. We're in business to build a product which is pretty much standard and to continue to build that product and let someone else worry about the options. I wish more of you could have the opportunity to see how the Aerostar is put together as opposed to some of the competitive models. I don't really call them competitive. I put them rather in a category of the same class of aircraft, the same size and load-carrying abilities, but that is where it stops. We have no competition in the Aerostar. It stands alone in the industry for superb performance and high integrity. It has a reputation of being the safest airplane on record with the National Transportation Bureau of Aeronautics. If you had the pieces spread out and could compare them one against the other, you would see what I am talking about. The Aerostar is far superior in its structures, in its characteristics and in its configuration. The aerodynamic factors in this aircraft are unbelievable as most of you have found out flying it. So there is really nothing to compare the Aerostar with directly, except to say it is a six-place airplane, it goes so fast, and it goes so far. If you take item for item, you will find the Aerostar far exceeds anything that is built by any other manufacturer. It sounds like I am blowing

a lot of horns here, but I sincerely mean what I say. We have a dynamic factor that we speak of as flutter speed. You will find that every airplane, including the Commander which I was responsible for, has a very minimum margin between flutter speed and maximum VD which is maximum dive speed. The FAA automatically reduces VD to VNE (which is never exceed speed) by a factor of approximately ten percent. But from VD to flutter speed in most aircraft, there is a very minimum margin, sometimes as low as 10 miles an hour and sometimes as high as 50 miles an hour. What do you find in the Aerostar? We have a VD of 300+ but we also have a flutter speed of 800 miles per hour which is over two and a half times greater. What does this mean to you? If you get into turbulence, most people reduce power to reduce speed in order to stay out of high dynamic load factors. Don't worry about it in the Aerostar. Fly it to the end of the yellow line and forget about it. It is not going to do any harm or get you into any trouble, and I don't care what the turbulence is, how heavy it is, or how intense it is. The aircraft is built to withstand it. We had a couple of incidents of a different kind. We had one about a month ago where a very competent pilot though he could take some short cuts in making IFR approach to Walla Walla, Washington, his final destination. Somehow he found a hole and broke out of the clouds, got down into a canyon with marginal visibility, ran into some power lines and ripped the vertical fin off the airplane. We read about this kind of thing all of the time. It is not the airplane's fault. It is the guy in the left seat who uses poor judgment. No airplane, no matter what it is, is going to forgive you for this type of flying. One of the biggest reasons for the accident rate in general aviation today is just this kind of thing. A guy can be an 8,000, 10,000, 15,000-hour pilot and sometimes he just forgets or gets overconfident. There are many thousands of general aviation accidents that are brought on by simply poor judgment in the cockpit. These you cannot blame on the airplane.

We have done one other thing with the Aerostar that we defy competition to match, and that is our war-



ranty on the airframe. We provide the first owner and even the second and the third owner with a 3,000 hour or 5-year life guarantee on the fixed portion of the airframe.

We have had, through other operations, experience with the Aerostar operating 24 hours a day in all environments of weather, ice, snow, sleet, whatever it might be, making landings every 15 to 20 minutes. Prior to using the Aerostar, these people were using a competitive product of the light skin structure. They found in the type of operation that they use the aircraft in, that 3,000 hours was the life of the aircraft, and that after 3,000 hours they just had to give them up. With their fleet of Aerostars, the first one went through the 3,000 hour inspection over two years ago, and it was just like it left the factory. They were asked one time, if they could not get Aerostars, what would they get. Their answer was that there is nothing they could buy that would give the reliability, the safety, and the service that they get from Aerostars. We have also other projects for the further growth of the Aerostar, so a person that buys an Aerostar today does not have to worry about growing up with the Aerostar family. All the way down the line for years to come, there will be improvements. Niels perhaps a little later will mention the tremendous number of improvements that you cannot see from the outside that have been made since we took the project back from Butler. They amount to hundreds of improvements, and we will continue to improve what we have today.

I'd like to take just a moment to recognize one of the dealers who started with us in the beginning in 1968 and who sold more Aerostars than any dealer or combination of dealers ever. He still continues to perform in that same way, simply, quietly, and he gets the job done. That person is Henry Weber, and I'd like Henry to step up here, and I'd like to give him a little memento. Henry, this is a picture of the three of us, you, my wife and myself. It was taken on the day that Henry took delivery of the first production airplane. Henry, we give you this with our kindest regards and thanks.

HENRY WEBER: Ted, thank you. I want to say in my life I have never been associated with a bunch of nicer people. Thank you.

TED SMITH: I'll turn the meeting back to Ron. Thank you very much.

RON SMITH

Brief supplemental report.

RON SMITH: I'd like to spend just a few moments with you. I know we are pressed for time to get back out to the hangar to see the rest of our final assembly line. I hope that you were impressed with what you saw today in the factory, the main plant. Hopefully some day we expect to all be in one facility. It is more convenient of course to have one facility for manufacturing, rather than two. However, we found it very easy to get along with the two facilities, primarily because of the way the Aerostar is built. We have a logical separation that makes it easy for us to move the airplane to the hangar in its semi-completed stage and finish the assembly there with the wings and the engines.

This last year we have progressed and moved approximately 3500 miles, from Texas to Reno, Nevada for a staging area, and then down to Van Nuys and to Santa Maria finally. We moved from three states and six facilities down to one town and two facilities, and went from 30 employees to a little over 230 right now. I am hopeful that we have now settled down. Just last month we moved in all of our wings which were still in storage in Reno. There aren't too many nooks and crannies where we haven't stored something. We are going to be gradually using this inventory in the next few months.

A few notes of significant interest. We just completed an audit by the FAA of our quality control system, and they are in the process of writing our production certificate accepting our quality control system. Thus, we are now able to make the conformity inspection of the airplanes ourselves and actually hang an airworthiness certificate in each airplane with our own staff rather than having to have the FAA fly each



airplane. So we are moving ahead.

We expect to increase our production rate for the balance of the year, in spite of the problems we are having with some of our vendors. We are, as they are, having problems obtaining materials. What was once two or three week lead times for materials are now two or three months or maybe as much as 16 to 18 months in cases of forgings and castings and things like this. I would like now to have our Engineering Manager, Niels Andersen, spend a few moments updating you as to what the new Aerostar offers to you as far as product improvement.

NIELS ANDERSEN

Report on engineering developments.

NIELS ANDERSEN: Thank you, Ron. Ladies and gentlemen, it is a real pleasure to meet with you again. I have a special place in my heart for the Aerostar Owners Association. When we picked up the Aerostar program, it had, as you know, been orphaned for approximately three years, and one of the first tasks was to try to find out the service history of the airplane. You people at the last year's meeting provided us that information. As you know, you have your yearly discussion about the Aerostar. I call it a free-for-all myself, because it is rough. But last year we sat and listened to you, and I recorded 28 items. Of those 28 items, after we studied them in detail, we felt that 20 of them should be corrected and we have done so. Some of the corrections you may not be aware of because they were not put out in service letters or service bulletins. The major ones which involved safety, you have been informed of.

As both Ron and TR pointed out, we have made changes in the Aerostar. Engineering wise we have made over a thousand changes. You will never see many of those changes. They involve details in fabrication, to make the airplane more producible, to speed up our manufacturing, and to reduce its cost to make it competitive.

As standard equipment on the new Aerostars, we have changed the engines from the G & P series to

the K & S series. What that means to an owner of a new Aerostar is 400 more hours between overhauls. We had some complaints regarding the electrical gyros on the airplane. We now have new dual pneumatic gyros. We had some comments regarding soundproofing. Today we have what we consider the best state of the art soundproofing. The present material is the same as that used on a Lockheed L-1011. It consists of a fiberglass batting which is water-repellent, and it is covered completely in a plastic sheet, and a panel fits inside each structural panel of the airplane. In some areas we also have a vinyl lead coating over this material, and we have managed to reduce the speech interference range by over 8 decibels. In theory this means we have almost cut the noise in half. Noise is something personal, which some people will notice and some not, but it is a very drastic change for those of you who have flown some of the new Aerostars versus the original Aerostar.

Now remember as I read these items to you that most of them are available as a retrofit. If you want to update your Aerostar, you can contact John MacNamara and he can schedule some of these items for you as a retrofit. We make a very definite effort, in anything that we develop to improve the airplane, to try to see that it is retrofittable. We do not try for planned obsolescence.

Regarding the heating of the airplane, we have improved the hot air distribution in the cabin. We have gone to a 70-amp alternator system versus the previous 50-amp system. Our basic avionics package is now a King Silver Crown package. ELTs of course are standard equipment. We have modified the engine three-way gauge. This was an item that concerned the Aerostar Owners Association last year. Tom Fifield discussed this with us, and so we issued a service bulletin which you all have.

We have a new fuel quantity system. This is again a latest state of the art system using the present probes you have now. We have improved the cabin latching mechanism and have put indicators on the cabin door. Some of you complained about the fuel tanks in hot weather, and we now provide a wing tank



pressure release system. We do not think this is the ultimate solution for this problem, but it is a first step. Some of you complained about lack of sealing on the nose compartment access door. This is now standard on all Aerostars, and we also have a sealed access cover in the wing aft of the exhaust stack. We had some incidents of bent nose-wheel steering bolts, and some bolts actually failed. We have replaced it with a higher strength bolt. Again, this was a service bulletin item. For the model 601, we now have turbocharger overboost valves as standard equipment. If any of you again are interested in obtaining them as a retrofit, we have them. We deleted the alternate induction air door for the turbocharger on the model 601. We found after testing with the FAA that this door actually was redundant and in some cases could even have been ingested into the turbochargers. Our new airplanes do not have that door, and this will be coming out in a service letter for retrofit. We had a switch in the model 601 for the turbocharger indicator lights, and we had quite a few incidents of malfunction of this switch. We have now rewired the motor internally to provide indication on the panel. This is in a service letter that you people should have received.

Wheels and brakes. This was an item of discussion at the last meeting, and Cleveland Aircraft Products came out with a new wheel for the airplane. That was a single caliper wheel. We did not consider that sufficient, so we worked with Cleveland and they have just finished obtaining a TSO for a wheel which we have now incorporated into production and which will be available as a retrofit. It is a dual caliper system. To give you an idea of the difference, the original brakes in the Aerostar were good for absorption of 600,000 foot pounds of kinetic energy. These new brakes are good for 800,000. This is in excess of what we need. We are now providing a strobe-light system instead of the rotating beacon as standard equipment, and we have the rotating beacon as optional if anyone wants it. Some of you requested an auxiliary hydraulic pump. We now have an electric driven auxiliary hydraulic pump available.

Some of the improvements we are working on involve items discussed at the last Aerostar Owners meeting. We are looking into an improved seal for the filler cap on the fuselage tank. We are looking at a new seal and a multiple lock for the baggage door. We have had one or two incidents where the baggage door has opened because it was not locked. We recommend that you always lock the baggage door, not just latch it. We now have a map light available. That was an item that was mentioned. As for radar — the KWX 40 King radar system is now available for the Aerostar. This again was an item which was discussed at the last owners meeting.

All this is just an outline of what we have worked on over this past year. What it boils down to is that you people as a group, when you found the Aerostar an orphan, joined to help yourselves by helping others. You have achieved this. You have provided us with information that we needed when we picked up this program and I want you to know that every bit of information you pass on to us we take very seriously. We study it and, if needed, we program it into our production. I know we are short for time and I will thank you once again.

NIELS ANDERSEN and BOB STRATTON (Janitrol) *Answers to various questions and discussion of heating system.*

VOICE: I have a question. I had my nose gear retract. It was a strong cross wind and I made a somewhat hard landing, but not that hard. The nose went down and wiped out the propellers and the nose gear. Do you have any comments concerning that structure? How many G's will it take?

BILL LEEDS: Aerostar nose gears were certified to the FAA for 6,000 pounds gross weight and 3 G's.

NIELS ANDERSEN: We have an option available that distributes the heat better. The heater in the Aerostar uses a single duct, and the upper half of the duct is cold air from the outside and the lower portion is hot air. As the hot air is going through this duct, it is losing some heat because you have cold



air right above it. We have changed the distribution system so we have more localized heat coming out. We also changed the ducting. It is a very simple mod. There is enough heat in the heater to really heat the airplane — far more than we really need.

NIELS ANDERSEN: We have had a couple of instances, right after servicing, with the airplane on the ground and towing it out of the hangar, where the nose gear folded. There was no hydraulic pressure. We had other incidents where, right after starting the engine, the thing folded. The only assumption we have to work with is that the gear handle was up. We started the engine, applied hydraulic pressure, and retracted the nose gear. We're looking at a new landing gear system, down locks and gear handle and so forth.

VOICE: Would it help to send back some of the parts to you now?

NIELS ANDERSEN: It would be a lot of help. Any time you have a problem with any piece of equipment, any part of the airplane, whatever it is, fill out one of our dealers' field service report forms. If you don't have access to one of those through a dealer, send us in writing exactly what happened. It is much better than calling over the phone. Just write down what happened to the best of your recollection and, if you have failed parts, send them in the mail to us. Once we see a repetitive type thing we know we have a problem, and having the parts and a description of what happened makes our job so much easier.

VOICE: Niels, I have a problem with descending. My hydraulic pressure reaches red line. It picks up pressure.

NIELS ANDERSEN: At one time we were going to change the hydraulic system to 1300 PSI for normal operation, and in fact we still may. Burst is 3,000 PSI. So if you are on red line, you don't really have to worry about it.

QUESTION: (on the subject of the heating system)

VOICE: Can I ask a question? Isn't it true that the duct is part of the outside skin in some places? Some-times the skin gets very hot outside.

NIELS ANDERSEN: No, the duct is separate from

the skin. If you look at a cross section of the heating duct that runs along the fuselage, it has little boxes on it. The idea there was to reduce noise. We knew we were going to have all this hot air blowing through and felt it was going to be noisy, so we had these chambers and the hot air was to go into them first and they are close to the skin. On the mod we do away with that. We reduce the loss with the new system, and we also localize the distribution of the air. The pilot's station has to be the coolest because it is farthest away from the source and the heat has to come clear around the airplane to get to you. This mod puts the outlet right at the pilots feet.

VOICE: We have another problem; we're too hot.

NIELS ANDERSEN: We put individual outlets at the seats, so the person sitting there can modulate how much air he wants coming out. (to Bob Stratton of Janitrol) You may want to mention the safety features and the different switches in the heater.

BOB STRATTON: Number one is the combustion air pressure switch. It makes sure you have combustion air pressure before you introduce fuel to the unit. That's the first safety feature. It is automatic. There is also a cycle switch that controls the temperature into your cabin. It cycles your unit on or off to maintain a certain heat let out from the unit through the distribution system. Now if that switch should fail, the unit will tend to overheat, and there is an overheat switch which will put the unit off. That has to be manually reset from outside the airplane

NIELS ANDERSEN: It's a little red button. It's on the forward portion of the heater, facing the skin. You'll have to get your hand behind the heater. You can't see it when you first look in because it's facing the skin. All you have to do is push the button down.

BOB STRATTON: We recommend that you try to find the cause before you push the button. The button is put there for this reason.

VOICE: My problem is that my heater fails when I try to light it on the ground. I light it in the air and everything is fine. The switch on the wing sticks three-quarters of the time. I've learned to freeze until I get in the air and then everything works.



VOICE: That switch does one thing only. It assures that the blower is running when the heater is on the ground.

BOB STRATTON: Do you understand why you have the problem? The switch does not allow you to use the blower for air on the ground. The reason it works in flight is because then you have ram air.

NIELS ANDERSEN: There's one thing you've got to make sure you do. Be sure your heat valve, that's the butterfly valve in the back of your cabin, is open so you have air circulation.

BOB STRATTON: One other thing that can happen is after landing. If you land with your heater on and leave it on so that the temperature of the heater is fairly high, and you turn your master off before your heater has cooled down, you have turned your ground blower off. Leave your master switch on until you can hear that ground blower cycling. It will shut itself off when the heater is cool, and then you shut your master off.

QUESTION: What is high time on heater units?

BOB STRATTON: So far we have seen no heaters returned from Aerostar owners. They should have a 500-hour overhaul, but we haven't seen any back. We recommend that they go back to the factory in Columbus. That takes about twenty days right now. We are trying to get this time down by means of an exchange program but we haven't reached that yet.

BOYD LYDICK and NIELS ANDERSEN

Answers to various questions

QUESTION: Changing the subject, I'd like to ask a question about operation of the turbos. In my 601 I make mostly very short flights. I heard it is best to keep the turbos running as much as possible. But let's say you are doing half-hour flights, and you are really not getting up to altitude. Would you still use them?

BOYD LYDICK: Yes sir, I would because I think lack of use is probably the greatest abuse that you can give the system. If you are up in the bay area, of course, you are too low to use them for take off.

What altitude do you go up to, 7500 or something like that? I wouldn't fly a 601 normally aspirated at that altitude because you are losing the benefit of the turbocharger system. The only other thing I'd say with the 601 is to take it to altitude occasionally and see if you have developed leaks in the system. You might end up with a 12 or 13,000-foot critical altitude, and when you need that altitude you don't have it. Go to 20 anyway, and see that the turbocharger is still functioning properly. All it needs to do is rotate. Some of the systems turn all the time for that purpose. So go ahead and put them on and get better life out of them. I would always do it at 7500 anyway. It gives you the chance to use a higher manifold pressure and lower RPM cruise setting anyway which is much more comfortable for the noise level.

QUESTION: Niels, do you have many service letters coming out? Can we keep from sweating for awhile?

NIELS ANDERSEN: We are considering one on the wheels and brakes. But again we don't want to get ourselves in the position of putting out a service letter that we cannot support because we don't have parts.

I don't think we have any other ones. I can assure you we do not put out a service bulletin or a service letter unless we honestly feel there is a problem. We do it only after very careful study. If we believe there is any hint of something being unsafe or being a major service problem, we let you know. That's all we can do.

QUESTION: Can you tell me how the 601-P is certified in regard to flight in icing conditions?

VOICE: No different from the 601. We do not have ice certification. It is a fairly extensive program to do that. It may be an outgrowth for some of our future programs, for instance with the jet.

QUESTION: Are there different degrees of icing? If you put boosts on or electric props, could you get partial certification?

NIELS ANDERSEN: Not that I'm aware of. As far as I know, ice certification is ice certification, and it's all weather.

QUESTION: Do you have any program in the mill to



correct the problem of fuel tank venting?

VOICE: Yes and no. We don't have any crash programs right now. We do have a file and as we come up with ideas, we keep putting them in it.

QUESTION: Have there been any changes since the first kits came out?

VOICE: No, we still have the same valves. One of the things that we're concerned about is the setting of the valves. The pressure release is set at 1-112 PSI. We would of course like to bring that down. One of the reasons is that that is as low as you can go and not spew fuel out under some flight conditions. But we are going to go back to the FAA and look into that. If we can show them that the amount of fuel is minimal, then maybe we can reduce that setting.

QUESTION: Could you go over the problems involved with the pressurization system? Why can't you use an expansion turbine and get air conditioning?

NIELS ANDERSEN: That's a good idea. The reason we can't is because the Aerostar has a sea level engine.

Its 29-1/2 inches is maximum manifold which means that we can't have the turbine putting out more than that pressure and operate with a full open throttle. If we had an engine set at 43 inches of manifold, we could get air conditioning on the ground by compressing the air first, cooling it and then expanding it. You have to have quite a high pressure. It has to be up in the 40s or so to really make it worthwhile. We can get this with the turbocharger. But if the turbocharger is putting out 40 inches of pressure, and you want to get 29-1/2 inches on the manifold pressure gage, you have to have your throttle valve three-quarters closed. To do what you were saying you would have to build a box into which all this high pressure air would go and then there would be another valve into a second box, and from that second box the air would go into the engine. It just gets too complicated to do.

THE END

@ YOUR SERVICE

AOA CONTACT INFORMATION
EXECUTIVE DIRECTOR
KEN BACON

AEROSTAR OWNERS ASSOCIATION
2608 WEST KENOSHA, #704
BROKEN ARROW, OK 74012

OFFICE PHONE / FAX
918.258.2346

HOT LINE (KEN BACON)
918.625.3161

AOA WEB SITE ADDRESS
www.aerostar-owners.com

KEN BACON EMAIL ADDRESS
KENBACONJR@COX.NET

We are here to listen and to improve the value of AOA to our members. Contact me directly concerning any Aerostar issue you may have (i.e., finding parts; getting you an AOA discount on parts; finding an Aerostar mechanic to assist your local mechanic, finding an overhaul facility for your parts, being an intermediary between you and a supplier). My personal goal is to save you, at a minimum, the annual membership fee through parts discounts, maintenance assistance, and discounts on insurance. So, let me hear from you!

Additionally, if you have an idea that would further improve our Association, then by all means, call me. If you need assistance with our web site or our membership services, then call my beautiful wife, Burdella, (Monday thru Friday 8AM CST to 5 PM CST).

Ken

DISCLAIMER: It is the policy of the Aerostar Owners Association that all Help Line suggestions be consistent with applicable FAA approved procedures, the FAA approved POH, Service Bulletins and Airworthiness Directives. Answers to technical questions are the best information available based on indications presented by the members asking the questions. Actual inspection of the airplane or system in question may change an initial telephone or email suggestion. Aircraft owners, pilots and readers are advised to physically present airplanes and indications to a qualified mechanic before choosing a course of action.



Introducing the Aerostar 702P

Take-Off Distance over 50ft.....	3,000 ft.
Maximum Cruise Speed.....	261 KTAS
Service Ceiling.....	FL 280
Maximum Ramp Weight.....	6,891 lbs.
Typical Empty Weight.....	4,650 lbs.
Typical Useful Load.....	2,241 lbs.
Max Usable Fuel Capacity.....	209.5 gal.
Max IFR Range, Full Fuel.....	1,050 nm.
Max Payload with Full Fuel.....	1,015 lbs.
Maximum Landing Weight.....	6,508 lbs.
Landing Distance over 50ft.....	2,400 ft.

Select one of our completed aircraft
in inventory or schedule your Aerostar
for an update to 702P specifications today.

Please call Jim Christy at Aerostar Aircraft Corporation.

800-442-4242

www.AerostarAircraft.com

CLASSIFIED ADS

AEROSTAR FLIGHT TRAINING Initial and Recurrent.
Insurance Approved Training Programs.
Contact: Dean Thomas at Pacific Aerostar L.L.C.
775-721-4618, www.pacific-aerostar.com

FLORIDA Spruce Creek Fly-In America's Premier Fly-In Community. A 4,000' paved, lighted runway 5/23, 13 miles of paved taxiways, Airport Identifier, 7FL6. An 18 hole par 72 Golf Course, Tennis Courts, Country Club, 24 hour security, 15 minutes from Daytona Beach International Airport. SPRUCE CREEK FLY-IN REALTY, servicing Spruce Creek Fly-In for over 20 years, attends several trade shows a year, reaching out to customers; staff of full time associates; open seven days a week. We sell all property, Hangar Homes, Homes on the Golf Course, Condominiums (some with planeports), Lots, and Rentals are available. Lenny Ohlsson, Broker.
Website: www.fly-in.com
Email: sales@fly-in.com
Phone: 1-800-932-4437
386-761-8804 (evenings)

CALENDAR

NBAA Light Business Airplane Exhibition and Conference Thursday March 12 to Saturday March 14 at San Diego, CA

AOA Spring Gathering San Diego, CA - will coincide with NBAA

AOA Fall 2009 Convention September 30-October 4, Colorado Springs, CO

ADVERTISING RATES

Classified Rates Classified advertising includes used aircraft, services and used equipment. Three column format (column width 2-3/16"). Regular line classified (42 typewritten characters per line - including spaces).

Per Regular Insertion: \$60.00
Oversize Classifieds: \$90.00

Publisher reserves the right to refuse or withdraw advertising. Payment must accompany order.

Display Rates **Full Page \$372.00**
1/2 Page \$216.00
1/4 Page \$144.00

Please call for cover rates / requirements.
Contact the Executive Director's Office at:
918.258.2346, info@aerostar-owners.com

ADVERTISERS INDEX

The Aerostar Owners Association appreciates the support of our advertisers. Please use their services whenever possible, and tell them you saw their ad in The Aerostar Log.

- 51 Aerostar Aircraft Corp.
- 07 Aerostar World, Inc.
- 07 Aviation Training Management
- 14 Bruce's Custom Covers
- 14 Business Aircraft Center
- 13 CS&A Aviation Insurance, Inc.
- 26 Krueger Aviation
- 26 November Whiskey, Inc.
- 39 Plastech Corporation
- 02 Recurrent Training Center
- 53 SIMCOM Training Centers
- 04 The Flight Shop
- 25 Zane Prits Aviation, Inc.



“Solid Value, Personalized Training and a Friendly Environment. That’s Why SIMCOM Customers Keep Coming Back!”



“Better *value* for every dollar spent. At SIMCOM, it’s just that simple. An instructor/student ratio of one-on-two provides a personal and effective training environment. And, having the same simulator and classroom instructor ensures greater training continuity. We also customize our programs to meet your schedule, needs and budget...to make it work for you.

Call **1-800-272-0211** today and schedule your next training event. Once you experience the *solid value*, *personalized training* and *friendly environment* at SIMCOM, we think you’ll be coming back, too.”

Wally David

Wally David, President
SIMCOM Training Centers

www.simulator.com

TURBOPROP & PISTON: Pilatus PC-12 • TBM 700/850 • Meridian • Malibu Mirage/Matrix • Mitsubishi MU-2 • King Air Duke • Baron • Twin Cessna • Cheyenne • Navajo • Aerostar • Seneca • Saratoga • Air Tractor
BUSINESS JET: Citation 500/550/560 Series • Citation CJ/CJ1/CJ2/CJ3 Series • Learjet 20/30/55 Series
Hawker 400XP/700/800/800XP Series • Beechjet 400 Series • MU-300 Series • Jetstream 41 • Dornier 328 Jet